

PLAN, OF SUBDIVISION		STAGE NO.	LTO use only EDITION 6	Plan Number PS 444154U
Location of Land Parish: MELBOURNE NORTH AT WEST MELBOURNE City: MELBOURNE Section: 40 Crown Allotment: 9PT, 9A, 23, 24 Title Reference: VOL 10631 FOL. 432 Last Plan Reference: PS 444154U LOT S2 Postal Address: 22-30 & 25-33 WILLS STREET (at time of subdivision) MELBOURNE 3000 AMG Co-ordinates E 320 060 ZONE: 55 (of approx. centre of land in plan) N 5813 040		Council Certification and Endorsement Council Name: CITY OF MELBOURNE Ref: TP 02/251126(1) 1. This plan is certified under section 6 of the Subdivision Act 1988. 2. This plan is certified under section 11(7) of the Subdivision Act 1988. Date of original certification under section 6 / / 3. This is a statement of compliance issued under section 21 of the Subdivision Act 1988. OPEN SPACE (i) A requirement for public open space under section 18 of the Subdivision Act 1988 has has not been made. (ii) The requirement has been satisfied. (iii) The requirement is to be satisfied in Stage..... Council Delegate _____ Council Seal _____ Date 25 / 10 / 02 Re-certified under section 11(7) of the Subdivision Act 1988. Council Delegate _____ Council Seal _____ Date / /		
APPLIES TO MASTER PLAN (STAGE 1) ONLY				
Vesting of Roads and / or Reserves				
Identifier	Council/Body/Person			
NIL	NIL			
Notations				
Staging		This is/is not a staged subdivision Planning Permit No. _____		
Depth Limitation		Varies, See Sections		
For other notations see sheet 2				
Survey This plan is/is not based on survey. This survey has been connected to permanent marks no(s). 23 in Proclaimed Survey Area No. _____				
Easement Information				
Legend: E - Encumbering Easement or Condition in Crown Grant in the Nature of an Easement A - Appurtenant Easement R - Encumbering Easement (Road)				LTO use only
Section 12(2) of the Subdivision Act 1988 applies to all of the land in this plan.				Statement of Compliance/ Exemption Statement
Subject Land	Purpose	Width (Metres)	Origin	Land Benefited/In Favour Of
E-1*	GAS SUPPLY	SEE DIAG	PS 444154U	ORIGIN ENERGY
E-2*	FIRE FIGHTING PURPOSES	SEE DIAG	PS 444154U	LAND IN PS 432495J
E-3*	LIGHT, AIR & DRAINAGE	SEE DIAG	PS 444154U	LAND IN PS 432495J
E-4*	WAY	SEE DIAG	PS 444154U	LAND IN PS 444154U
E-5*	SEWERAGE	SEE DIAG	PS 444154U	CROWN GRANT VOL.5809 FOL.796
				Received <input checked="" type="checkbox"/> Date / /
				THIS IS A LAND REGISTRY COMPILED PLAN CHECKED: 11/12/2002 GREG NEWMAN..... Assistant Registrar of Titles Sheet 1 of 67 Sheets
BEVERIDGE WILLIAMS & CO. PTY.LTD. ACN 006 187 235 ABN 44 622 029 694 SURVEYORS, ENGINEERS, PLANNERS ENVIRONMENTAL CONSULTANTS PO BOX 2205 CAULFIELD JUNCTION 3161 95284444 PO BOX 1465 BALLARAT MAIL CENTRE 3354 53313877 PO BOX 161 LEONCATHA 3953 56622630 PO BOX 128 WORTHAGGI 3995 56721505 PO BOX 1916 TRARALGON 3844 51760374		LICENSED SURVEYOR JOHN FRANCIS WILLIAMS (PRINT)		
		SIGNATURE _____ DATE 30/09/2002 REF. 8455/2A K:\DATA\8455\8455pss2.DGN VERSION 2		DATE 25 / 10 / 02 COUNCIL DELEGATE SIGNATURE _____ Original sheet size A3

PLAN OF SUBDIVISION

Stage No.

Plan Number

PS 444154U

REDUCED LEVELS SHOWN THUS R.L. 47-50 ARE TO AHD.
LEVEL DATUM POINT USED WAS PM 23 OF R.L. 24-576 AT 14/10/1999.

BOUNDARIES SHOWN BY THICK CONTINUOUS LINES ARE DEFINED BY BUILDINGS.

LOCATION OF BOUNDARIES DEFINED BY BUILDINGS

- MEDIAN - BOUNDARIES MARKED M
- EXTERIOR FACE - BOUNDARIES MARKED E
- NORTH FACE - BOUNDARIES MARKED N
- EAST FACE - BOUNDARIES MARKED EF
- WEST FACE - BOUNDARIES MARKED W
- SOUTH FACE - BOUNDARIES MARKED S
- INTERIOR FACE - ALL OTHER BOUNDARIES

LOT NUMBERS 1 TO 200, T1 TO T100, T102 TO T200, T204, T208 TO T300, T304, T308 TO T400, T404, T408 TO T500, T504, T508 TO T600, T604, T608 TO T700, T704, T708 TO T800, T804, T808 TO T900, T904, T908 TO T1000, T1004, T1008 TO T1100, T1104, T1108 TO T1200, T1204, T1208 TO T1400, T1404, T1408 TO T1500, T1504, T1508 TO T1600, T1604, T1608 TO T1700, T1704, T1708 TO T1800, T1804, T1808 TO T1900, T1904 TO T2000, T2004 TO T2100, T2104 TO T2200, T2204 TO T2300, T2304 TO T2400, T2404 TO T2500, T2504 TO T2600, T2604 TO T2700, C1 TO C100, C104 TO C200, C204 TO C300, C304 TO C400, C404 TO C500, C504 TO C600, C604 TO C700, C704 TO C800, C804 TO C900, C904 TO C1000, C1004 TO C1100, C1104 TO C1200, C1204 TO C1300, C1304 TO C1400, C1404 TO C1500, C1504 TO C1600, C1604 TO C1700, C1704 TO C1800, C1804 TO C1900, C1904 TO C2000, C2004 TO C2100, C2104 TO C2200, C2204 TO C2300 & C2304 TO C2400 HAVE BEEN OMITTED FROM THIS PLAN.

ALL STRUCTURAL WALLS, SLABS, COLUMNS & BEAMS AND ALL INTERNAL SERVICE DUCTS AND PIPE SHAFTS BELOW R.L. 24-93m ARE CONTAINED IN C.P.No.2 UNLESS OTHERWISE NOTED

ALL STRUCTURAL WALLS, SLABS, COLUMNS & BEAMS AND ALL INTERNAL SERVICE DUCTS AND PIPE SHAFTS ABOVE R.L. 24-93m & EAST OF WILLS STREET ARE CONTAINED IN C.P.No.3 UNLESS OTHERWISE NOTED

ALL STRUCTURAL WALLS, SLABS, COLUMNS & BEAMS AND ALL INTERNAL SERVICE DUCTS AND PIPE SHAFTS ABOVE R.L. 24-93m & WEST OF WILLS STREET ARE CONTAINED IN C.P.No.4 UNLESS OTHERWISE NOTED



BEVERIDGE WILLIAMS & CO. PTY.LTD.
ACN 006 197 235 ABN 44 622 029 694
SURVEYORS, ENGINEERS, PLANNERS
ENVIRONMENTAL CONSULTANTS
PO BOX 2205 CAULFIELD JUNCTION 3161 95284444
PO BOX 1465 BALLARAT MAIL CENTRE 3354 53313877
PO BOX 161 LEDGATHA 3953 56622630
PO BOX 129 WONTHAGGI 3995 56721505
PO BOX 1916 TRARALGON 3844 51760374

Sheet 2 of 67 Sheets

ORIGINAL SCALE	SHEET SIZE A3	SCALE 0 LENGTHS ARE IN METRES	LICENSED SURVEYOR (PRINT) JOHN FRANCIS WILLIAMS	DATE 17/11/2003	DATE / /
			SIGNATURE	VERSION 3	COUNCIL DELEGATE SIGNATURE
			REF. 8455/3 K:\DATA\8455\8455pss3.DGN		Original sheet size A3

PLAN OF SUBDIVISION

Stage No.

Plan Number

PS 444154U

A'BECKETT STREET

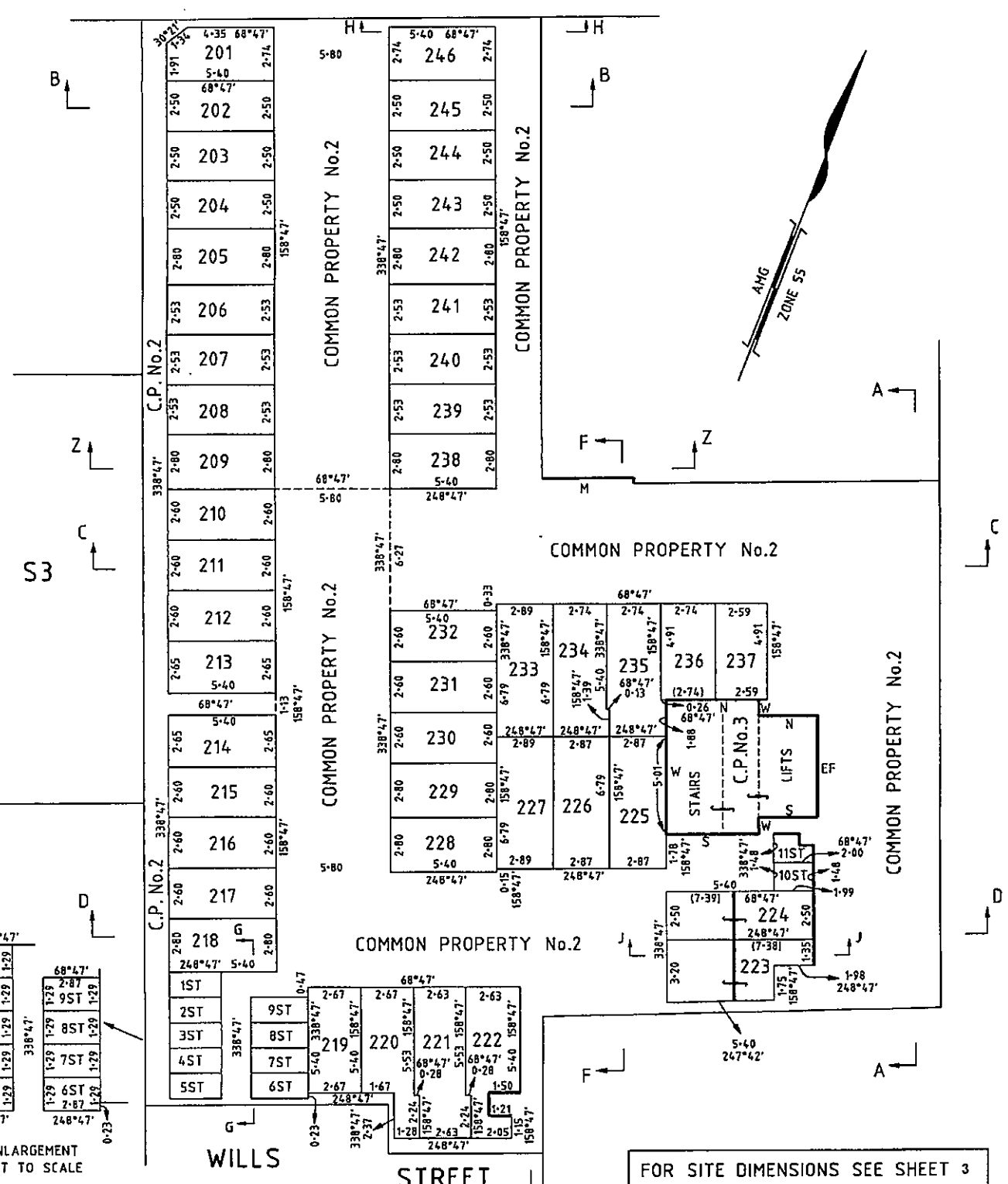

S3

FOR SITE DIMENSIONS SEE SHEET 3



BEVERIDGE WILLIAMS & CO. PTY.LTD.
 ACN 006 197 235 ABN 44 622 029 694
 SURVEYORS ENGINEERS PLANNERS
 ENVIRONMENTAL CONSULTANTS
 PO BOX 2205 CAULFIELD JUNCTION 3161 95284444
 PO BOX 1465 BALLARAT MAIL CENTRE 3354 53313877
 PO BOX 161 LEONGATHA 3953 56622630
 PO BOX 129 WONTHAGGI 3995 56721505
 PO BOX 1916 TRARALGON 3844 51760374

BASEMENT LEVEL FOUR

ORIGINAL
 SCALE SHEET SIZE
 1:200 A3

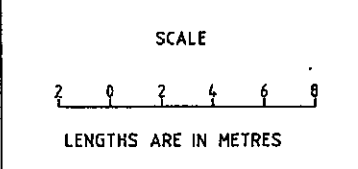

LICENSED SURVEYOR JOHN FRANCIS WILLIAMS
 (PRINT)
 SIGNATURE _____ DATE 30/09/2002
 REF. 8455/2A
 K:\DATA\8455\8455pss2.DGN VERSION 2

Sheet 4 of .67 Sheets
 DATE / /
 COUNCIL DELEGATE SIGNATURE
 Original sheet size A3

PLAN OF SUBDIVISION

Stage No.

Plan Number

PS 444154U

A'BECKETT STREET

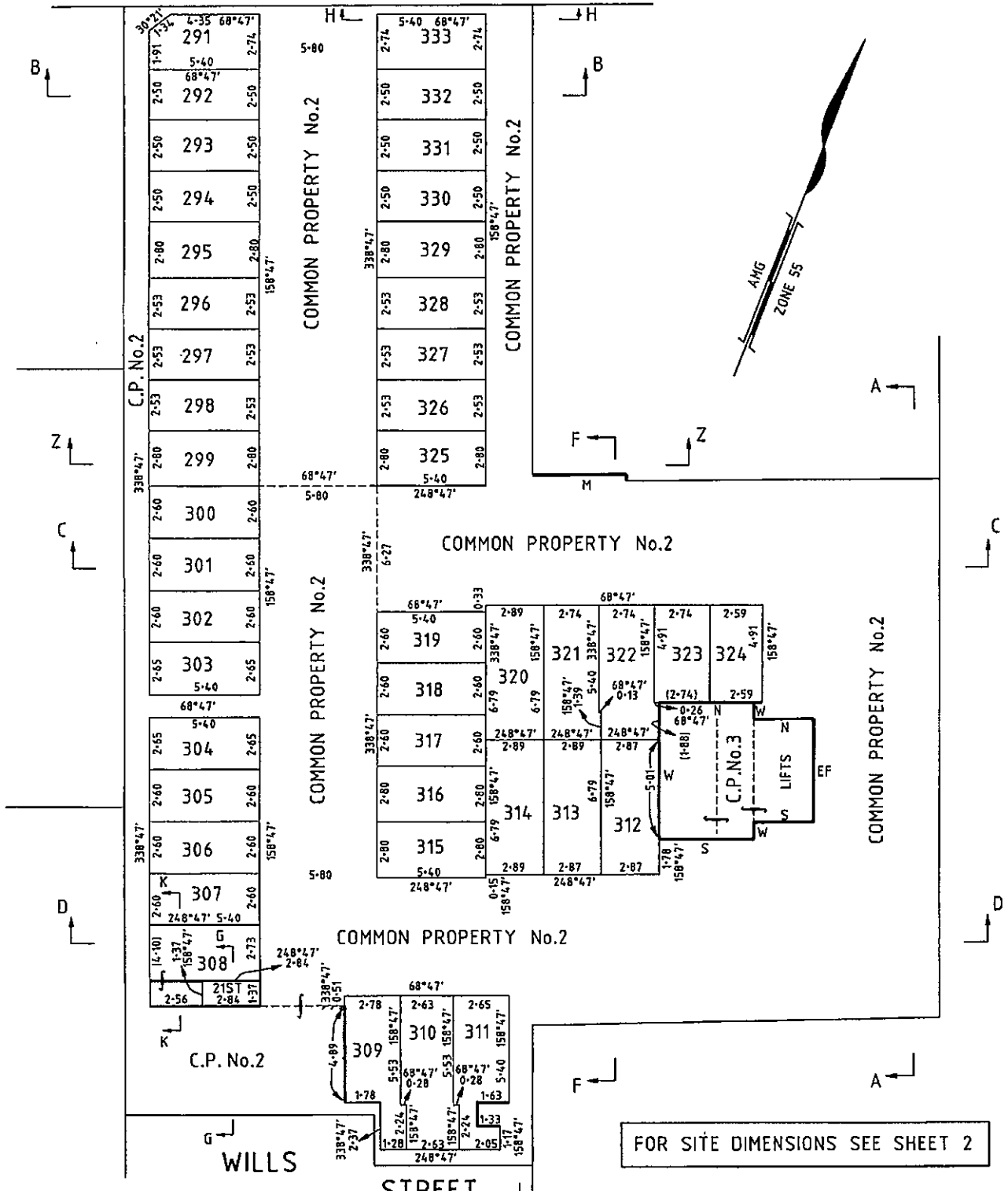

BEVERIDGE WILLIAMS & CO. PTY.LTD.
 ACN 006 197 235 ABN 44 622 028 694
SURVEYORS . ENGINEERS . PLANNERS
ENVIRONMENTAL CONSULTANTS
 PO BOX 2205 CAULFIELD JUNCTION 3161 95284444
 PO BOX1465 BALLARAT MAIL CENTRE 3354 53313877
 PO BOX 161 LEONGATHA 3953 56622630
 PO BOX 129 WONTHAGGI 3995 56721505
 PO BOX 1916 TRARALGON 3844 51760374

BASEMENT LEVEL TWO

ORIGINAL
 SCALE SHEET SIZE
 1:200 A3

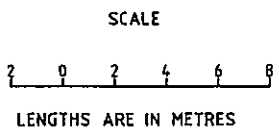

LICENSED SURVEYOR JOHN FRANCIS WILLIAMS
 (PRINT)
 SIGNATURE _____ DATE 30/09/2002
 REF. 8455/2A
 K:\DATA\8455\8455pss2.DGN VERSION 2

Sheet 6 of 67 Sheets
 DATE / /
 COUNCIL DELEGATE SIGNATURE
 Original sheet size A3

PLAN OF SUBDIVISION Stage No. Plan Number
PS 444154U

A'BECKETT STREET

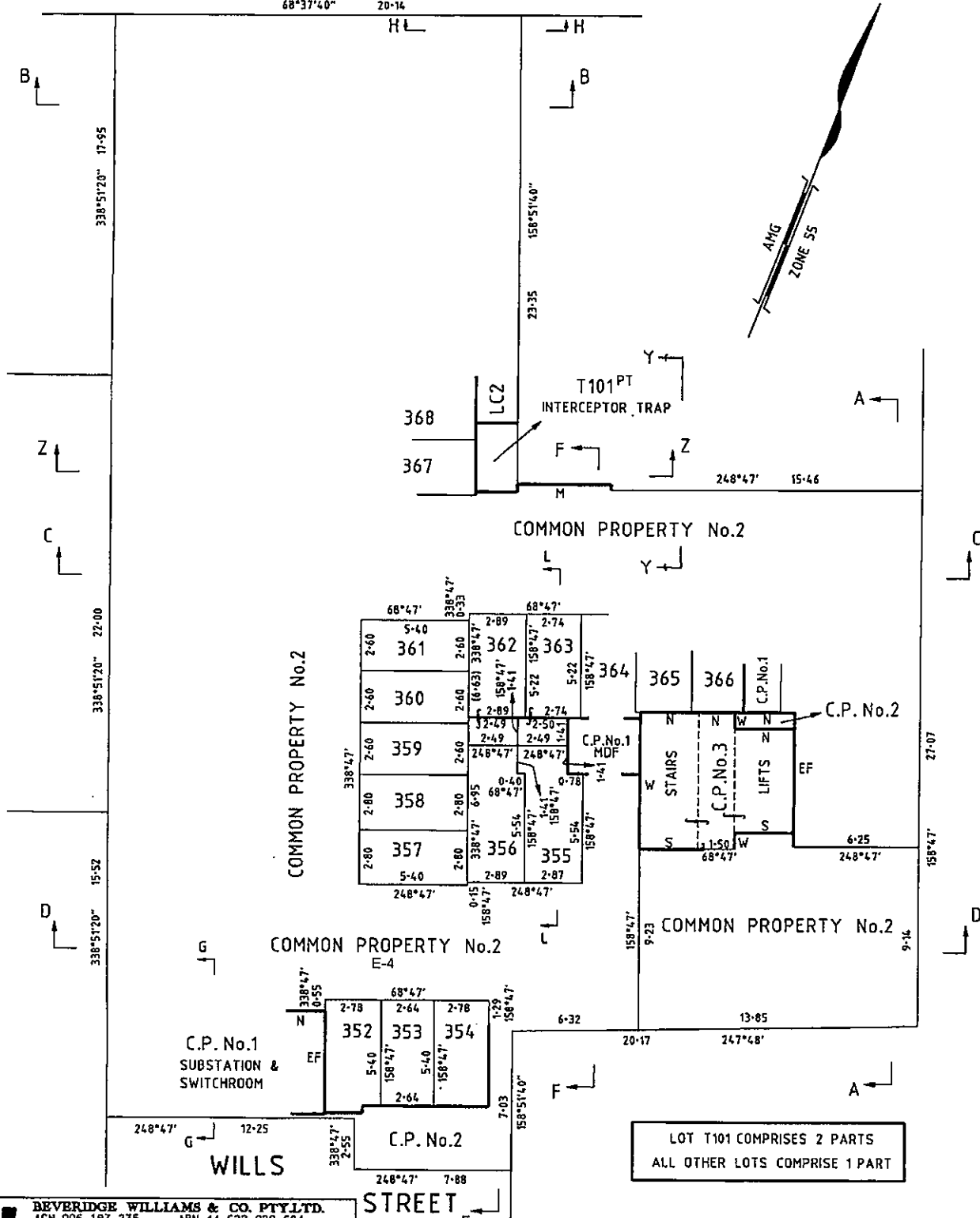

BW BEVERIDGE WILLIAMS & CO. PTY.LTD.
 ACH 006 197 235 ABN 44 622 029 694
 SURVEYORS, ENGINEERS, PLANNERS
 ENVIRONMENTAL CONSULTANTS
 PO BOX 2205 CAULFIELD JUNCTION 3161 95284444
 PO BOX 1465 BALLARAT MAIL CENTRE 3354 53313877
 PO BOX 161 LEONGATHA 3953 56622630
 PO BOX 129 WINTHROP 3995 56721505
 PO BOX 1916 TRARALGON 3844 51760374

BASEMENT LEVEL ONE
(CONTINUED FROM SHEET 6)

ORIGINAL SCALE	SCALE	LICENSED SURVEYOR JOHN FRANCIS WILLIAMS (PRINT)	Sheet 8 of 67 Sheets
SCALE 1:200	<p>LENGTHS ARE IN METRES</p>	SIGNATURE _____ DATE 30/09/2002	DATE / /
SHEET SIZE A3		REF. 8455/2A K:\DATA\8455\8455pss2.DGN	COUNCIL DELEGATE SIGNATURE _____
		VERSION 2	Original sheet size A3

PLAN OF SUBDIVISION

Stage No.

Plan Number

PS 444154U

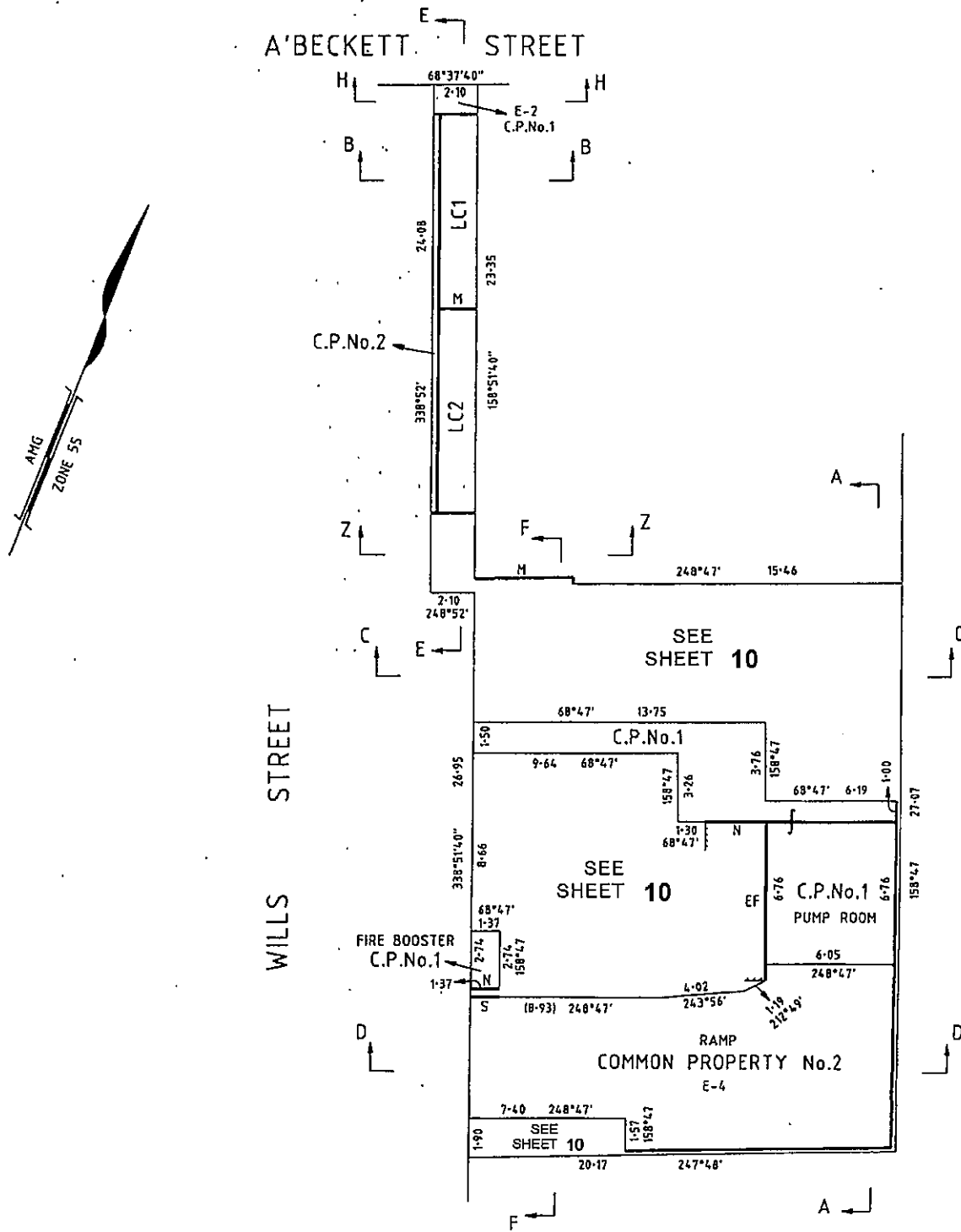

LEVEL ONE



BEVERIDGE WILLIAMS & CO. PTY.LTD.
 ACN 006 197 235 ABN 44 622 029 694
SURVEYORS ENGINEERS PLANNERS
 ENVIRONMENTAL CONSULTANTS
 PO BOX 2205 CAULFIELD JUNCTION 3161 95284444
 PO BOX 1465 BALLARAT MAIL CENTRE 3354 53313877
 PO BOX 161 LEONGATHA 3953 56622630
 PO BOX 129 WONTHAGGI 3995 56721505
 PO BOX 1916 TRARALGON 3844 51760374

Sheet 9 of 67 Sheets

ORIGINAL	SCALE
SCALE	SHEET SIZE
1:200	A3
<p>LENGTHS ARE IN METRES</p>	

LICENSED SURVEYOR JOHN FRANCIS WILLIAMS
 (PRINT)
 SIGNATURE _____ DATE 13/12/2001
 REF. 8455/2
 K:\DATA\8455\8455psst.DGN VERSION 5

DATE / /
 COUNCIL DELEGATE SIGNATURE
 Original sheet size A3

PLAN OF SUBDIVISION	Stage No.	Plan Number
		PS 444154U

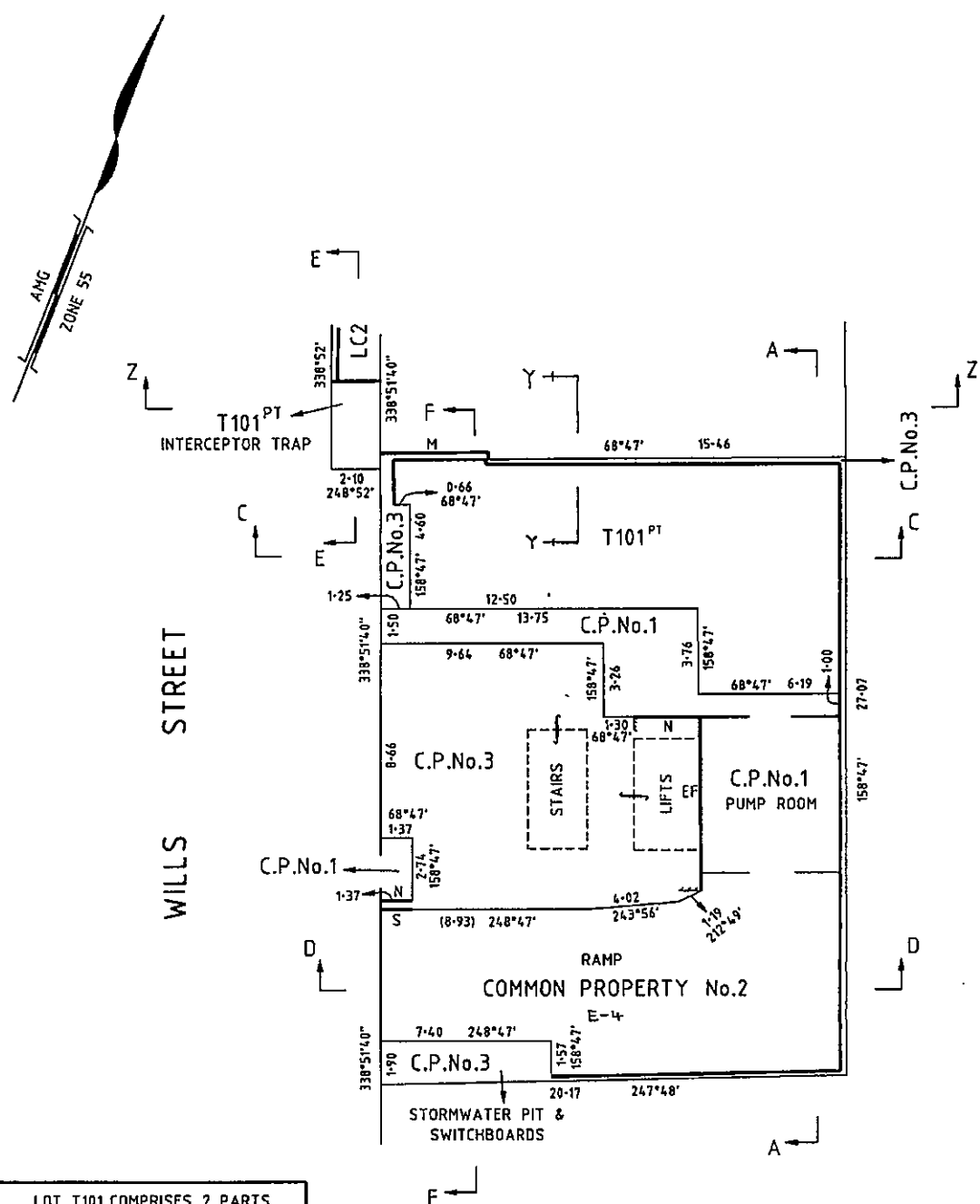

LOT T101 COMPRISES 2 PARTS
 ALL OTHER LOTS COMPRISE 1 PART

LEVEL ONE

BW BEVERIDGE WILLIAMS & CO. PTY.LTD.
 ACN 006 197 235 ABN 44 622 029 694
 SURVEYORS . ENGINEERS . PLANNERS
 ENVIRONMENTAL CONSULTANTS
 PO BOX 2205 CAULFIELD JUNCTION 3161 95284444
 PO BOX1465 BALLARAT MAIL CENTRE 3354 53313877
 PO BOX 161 LEONGATHA 3953 56622630
 PO BOX 129 WONTHAGGI 3995 56721505
 PO BOX 1916 TRARALGON 3844 51760374

ORIGINAL	SCALE	
SCALE	SHEET SIZE	LICENSED SURVEYOR <u>JOHN FRANCIS WILLIAMS</u> (PRINT)
1:200	A3	SIGNATURE _____ DATE 30/09/2002 REF. 8455/2A K:\DATA\8455\8455pss2.DGN
	LENGTHS ARE IN METRES 	VERSION 2

Sheet 10 of 67 Sheets
DATE / /
COUNCIL DELEGATE SIGNATURE
Original sheet size A3

PLAN OF SUBDIVISION	Stage No.	Plan Number PS 444154U
----------------------------	-----------	----------------------------------

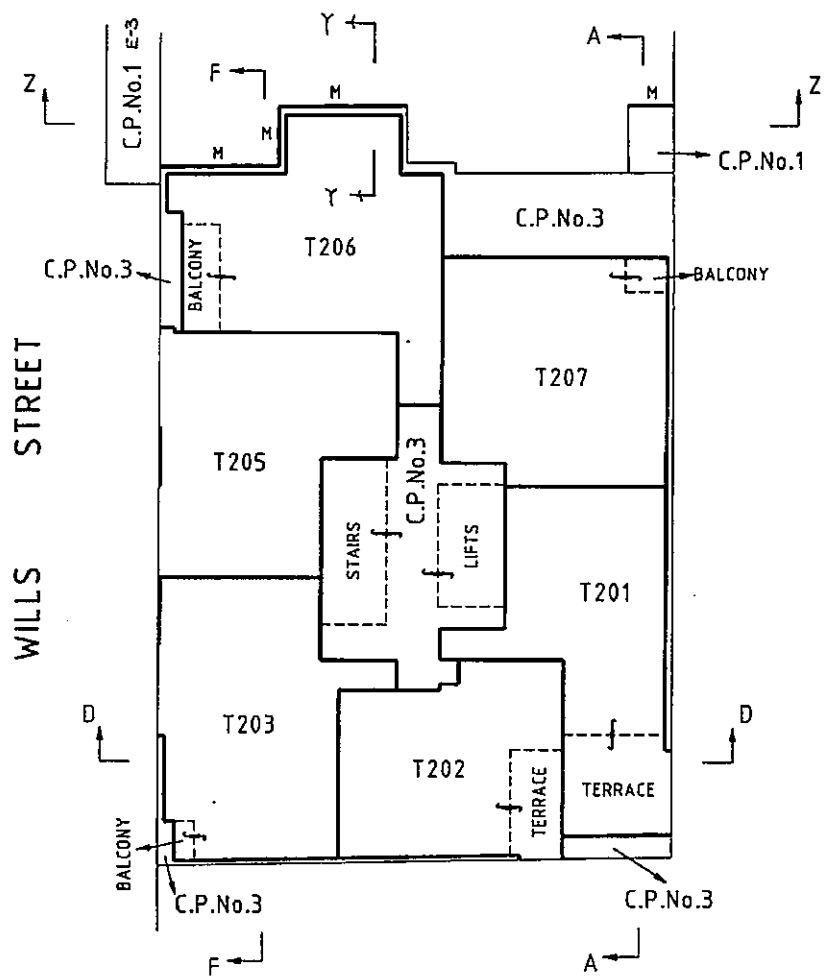
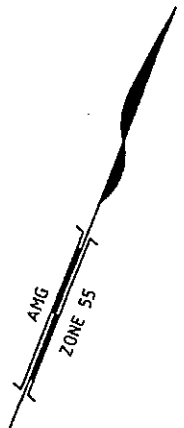

FOR SITE DIMENSIONS SEE SHEET 2

LEVEL TWO

BW BEVERIDGE WILLIAMS & CO. PTY.LTD.
 ACH 006 197 235 ABN 44 622 029 694
 SURVEYORS ENGINEERS PLANNERS
 ENVIRONMENTAL CONSULTANTS
 PO BOX 2205 CAULFIELD JUNCTION 3161 95284444
 PO BOX 1465 BALLARAT MAIL CENTRE 3354 53313677
 PO BOX 161 LEONGATHA 3953 56622630
 PO BOX 129 WONTHAGGI 3995 56721505
 PO BOX 1916 TRARALGON 3844 51760374

ORIGINAL		LICENSED SURVEYOR <u>JOHN FRANCIS WILLIAMS</u> (PRINT)	
SCALE	SHEET SIZE	SIGNATURE _____	DATE 30/09/2002
1 : 200	A3	REF. 8455/2A	COUNCIL DELEGATE SIGNATURE _____
SCALE LENGTHS ARE IN METRES		K:\DATA\8455\8455pss2.DGN	VERSION 2
			Sheet 11 of 67 Sheets
			Original sheet size A3

PLAN OF SUBDIVISION	Stage No.	Plan Number PS 444154U
---------------------	-----------	----------------------------------

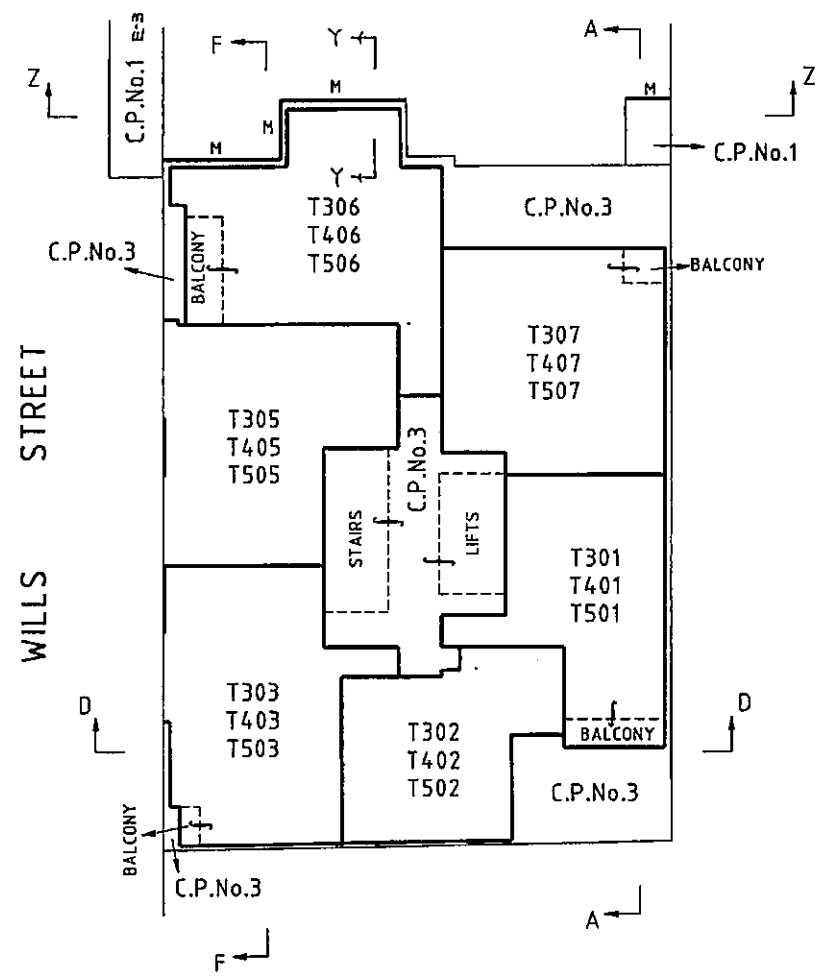
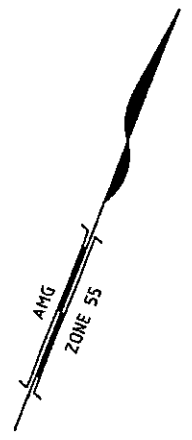

LEVELS THREE, FOUR & FIVE

BW
 BEVERIDGE WILLIAMS & CO. PTY.LTD.
 ACN 006 197 235 ABN 44 622 029 694
 SURVEYORS, ENGINEERS, PLANNERS,
 ENVIRONMENTAL CONSULTANTS
 PO BOX 2205 CAULFIELD JUNCTION 3161 95284444
 PO BOX 1485 BALLARAT MAIL CENTRE 3354 53313877
 PO BOX 161 LEDNAGATHA 3953 56622630
 PO BOX 129 WORTHAGGI 3995 56721505
 PO BOX 1916 TRARALGON 3844 51760374

Sheet 12 of 67 Sheets

DATE / /

COUNCIL DELEGATE SIGNATURE

Original sheet size A3

ORIGINAL	SCALE	LICENSED SURVEYOR <u>JOHN FRANCIS WILLIAMS</u>	
SCALE	<p>LENGTHS ARE IN METRES</p>	SIGNATURE _____	DATE 30/09/2002
1 : 200		REF. 8455/2A	VERSION 2
SHEET SIZE		K:\DATA\8455\8455pss2.DGN	
A3			

PLAN OF SUBDIVISION	Stage No.	Plan Number PS 444154U
---------------------	-----------	----------------------------------

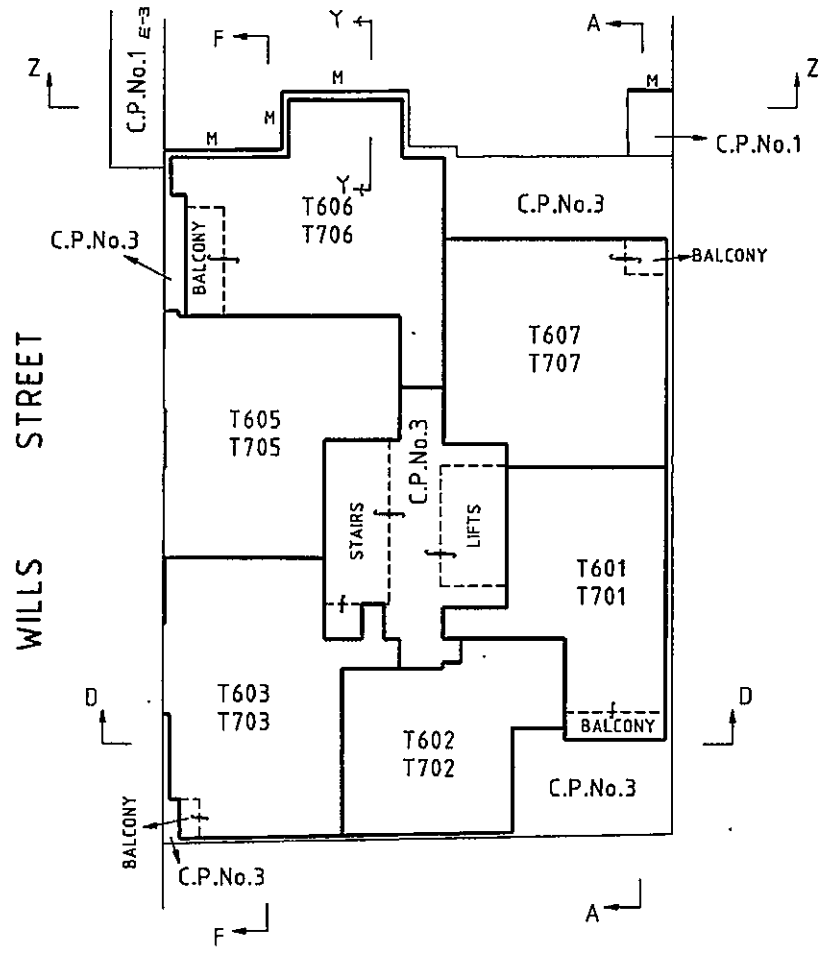
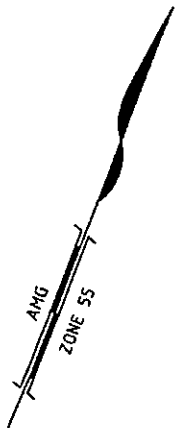

LEVELS SIX & SEVEN

BW
BEVERIDGE WILLIAMS & CO. PTY.LTD.
 ACN 006 197 235 ABN 44 622 029 694
 SURVEYORS, ENGINEERS, PLANNERS
 ENVIRONMENTAL CONSULTANTS
 PO BOX 2205 CAULFIELD JUNCTION 3161 95284444
 PO BOX 1465 BALLARAT MAIL CENTRE 3354 53313877
 PO BOX 161 LEONGATHA 3953 56622630
 PO BOX 129 WORTHAGGI 3995 56721505
 PO BOX 1916 TRARALGON 3844 51760374

Sheet 13 of 67 Sheets	
DATE / /	COUNCIL DELEGATE SIGNATURE
Original sheet size A3	

ORIGINAL	SCALE	LICENSED SURVEYOR <u>JOHN FRANCIS WILLIAMS</u> (PRINT)	DATE 30/09/2002
SCALE 1:200	 LENGTHS ARE IN METRES	SIGNATURE _____	DATE 30/09/2002
SHEET SIZE A3		REF. 8455/2A	VERSION 2

K:\DATA\8455\8455pss2.DGN

PLAN OF SUBDIVISION	Stage No.	Plan Number PS 444154U
---------------------	-----------	----------------------------------

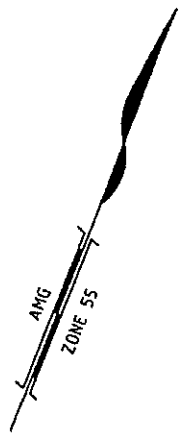

WILLS STREET

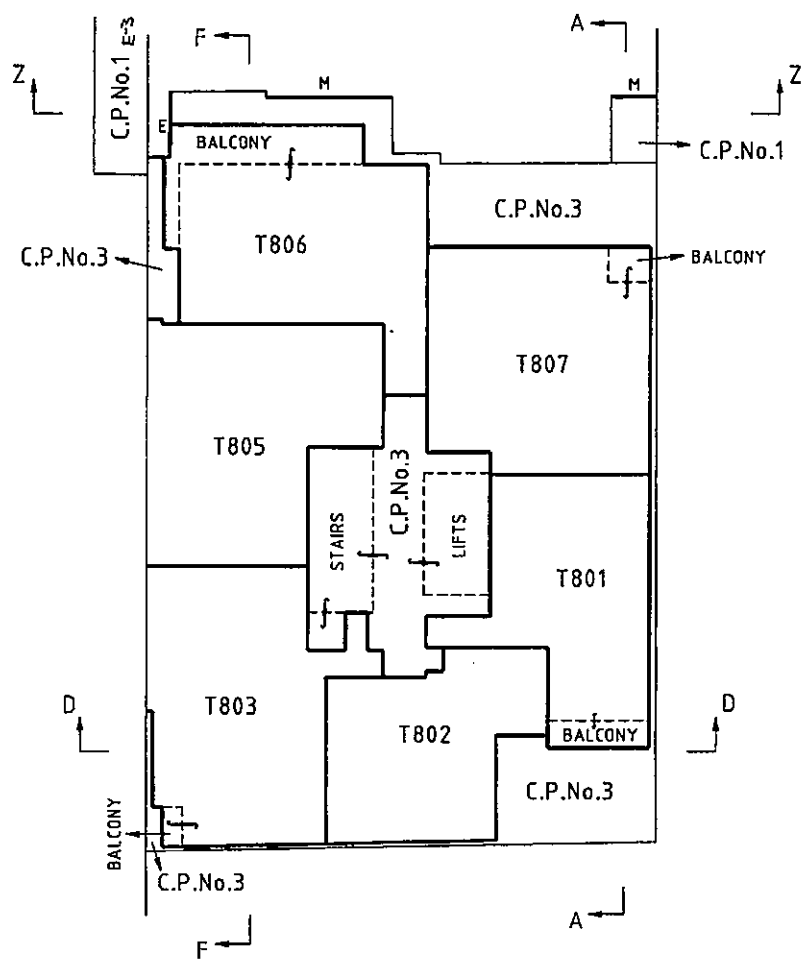

LEVEL EIGHT

BW BEVERIDGE WILLIAMS & CO. PTY.LTD.
 ACN 006 197 235 ABN 44 822 029 894
 SURVEYORS, ENGINEERS, PLANNERS
 ENVIRONMENTAL CONSULTANTS
 PO BOX 2205 CAULFIELD JUNCTION 3161 95284444
 PO BOX 1465 BALLARAT MAIL CENTRE 3354 53313877
 PO BOX 161 LEONGATHA 3953 56622630
 PO BOX 129 MONTHAGDI 3995 56721505
 PO BOX 1916 TRARALGON 3844 51760374

Sheet 14 of 67 Sheets

DATE / /

COUNCIL DELEGATE SIGNATURE

Original sheet size A3

ORIGINAL		SCALE	LICENSED SURVEYOR <u>JOHN FRANCIS WILLIAMS</u> (PRINT)
SCALE	SHEET SIZE	<p>LENGTHS ARE IN METRES</p>	SIGNATURE _____ DATE 30/09/2002
1:200	A3		REF. 8455/2A K:\DATA\8455\8455pss2.DGN

	VERSION 2
--	-----------

PLAN OF SUBDIVISION	Stage No.	Plan Number PS 444154U
---------------------	-----------	----------------------------------

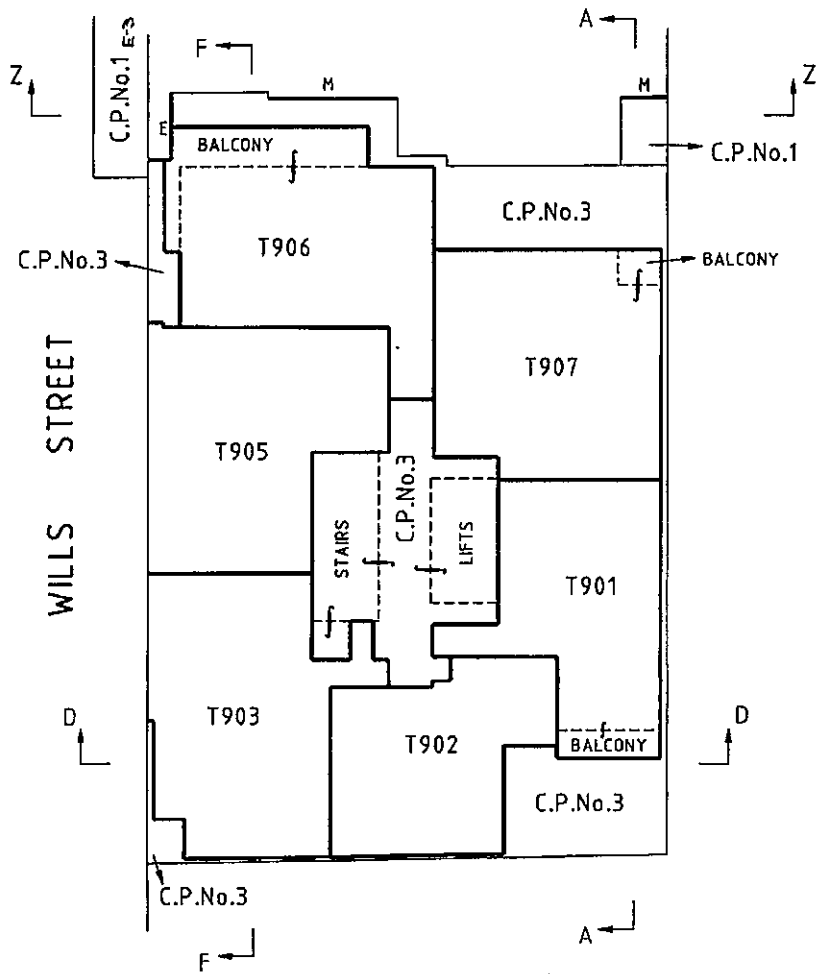
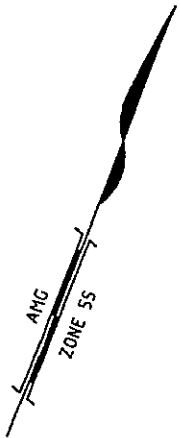

LEVEL NINE



BEVERIDGE WILLIAMS & CO. PTY.LTD.
 ACN 006 197 235 ABN 44 622 029 694
 SURVEYORS, ENGINEERS, PLANNERS
 ENVIRONMENTAL CONSULTANTS
 PO BOX 2205 CAULFIELD JUNCTION 3161 95284444
 PO BOX 1465 BALLARAT MAIL CENTRE 3354 53313877
 PO BOX 161 LEDNAGATHA 3953 56622630
 PO BOX 129 WINTHAGGI 3985 56721505
 PO BOX 1916 TRARALGON 3844 51760374

Sheet 15 of 67 Sheets

ORIGINAL SCALE 1:200	SHEET SIZE A3	SCALE LENGTHS ARE IN METRES	LICENSED SURVEYOR <u>JOHN FRANCIS WILLIAMS</u> (PRINT) SIGNATURE _____ DATE <u>30/09/2002</u> REF. <u>8455/2A</u> K:\DATA\8455\8455pss2.DGN VERSION <u>2</u>	DATE / / COUNCIL DELEGATE SIGNATURE Original sheet size A3
------------------------------------	----------------------	--	---	--

PLAN OF SUBDIVISION	Stage No.	Plan Number PS 444154U
---------------------	-----------	----------------------------------

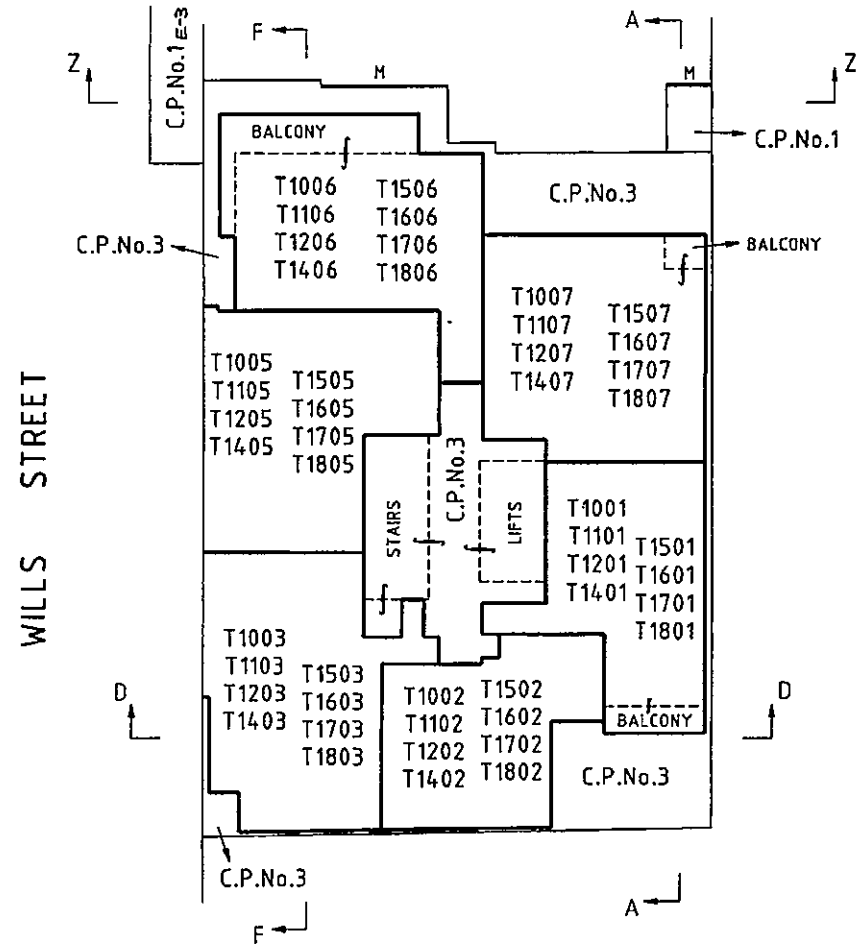
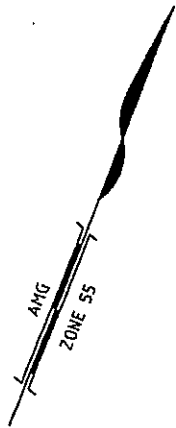

**LEVELS TEN, ELEVEN, TWELVE, FOURTEEN,
FIFTEEN, SIXTEEN, SEVENTEEN AND EIGHTEEN**

BW BEVERIDGE WILLIAMS & CO. PTY.LTD.
 ACN 006 197 235 ASN 44 622 029 694
 SURVEYORS, ENGINEERS, PLANNERS
 ENVIRONMENTAL CONSULTANTS
 PO BOX 2205 CAULFIELD JUNCTION 3161 95284444
 PO BOX 1465 BALLARAT MAIL CENTRE 3354 53313877
 PO BOX 161 LEONGATHA 3953 56622630
 PO BOX 129 WINTHAGGI 3995 56721505
 PO BOX 1916 TRARALGON 3844 51760374

ORIGINAL
 SCALE 1:200
 SHEET SIZE A3

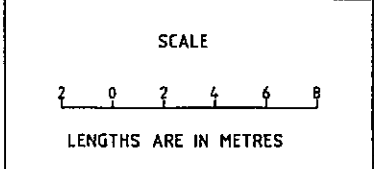

LICENSED SURVEYOR JOHN FRANCIS WILLIAMS
 (PRINT)
 SIGNATURE DATE 30/09/2002
 REF. 8455/2A
 K:\DATA\8455\8455pss2.DGN VERSION 2

Sheet 16 of 67 Sheets

DATE / /

COUNCIL DELEGATE SIGNATURE

Original sheet size A3

PLAN OF SUBDIVISION

Stage No.

Plan Number

PS 444154U

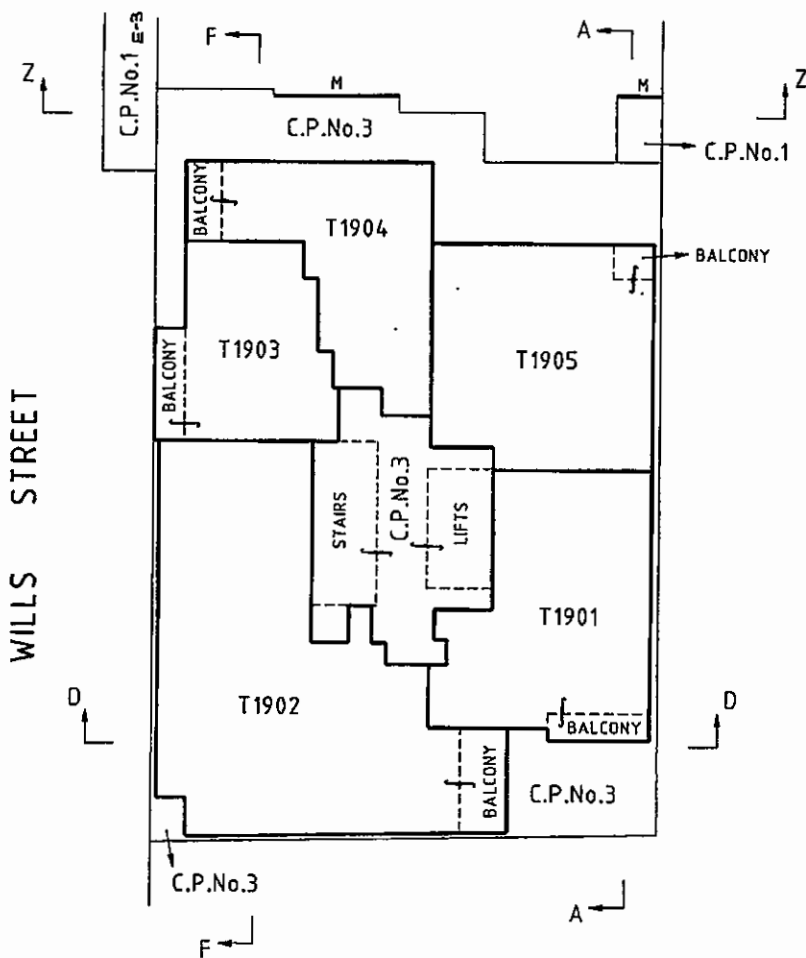
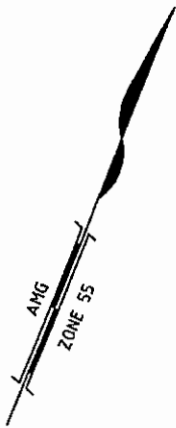

WILLS STREET

LEVEL NINETEEN



BEVERIDGE WILLIAMS & CO. PTY.LTD.
 ACN 006 197 235 ABN 44 622 029 694
 SURVEYORS . ENGINEERS . PLANNERS
 ENVIRONMENTAL CONSULTANTS
 PO BOX 2205 CAULFIELD JUNCTION 3161 95284444
 PO BOX 1465 BALLARAT MAIL CENTRE 3354 53313877
 PO BOX 161 LEONGATHA 3953 56622630
 PO BOX 129 WONTHAGGI 3995 56721505
 PO BOX 1916 TRARALGON 3844 51760374

Sheet 17 of 67 Sheets

ORIGINAL	SCALE
SCALE	SHEET SIZE
1:200	A3

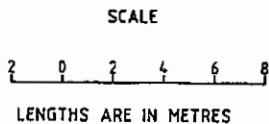

LICENSED SURVEYOR JOHN FRANCIS WILLIAMS
 (PRINT)
 SIGNATURE _____ DATE 30/09/2002
 REF. 8455/2A
 K:\DATA\8455\8455pss2.DGN VERSION 2

DATE / /
 COUNCIL DELEGATE SIGNATURE
 Original sheet size A3

PLAN OF SUBDIVISION	Stage No.	Plan Number PS 444154U
----------------------------	-----------	----------------------------------

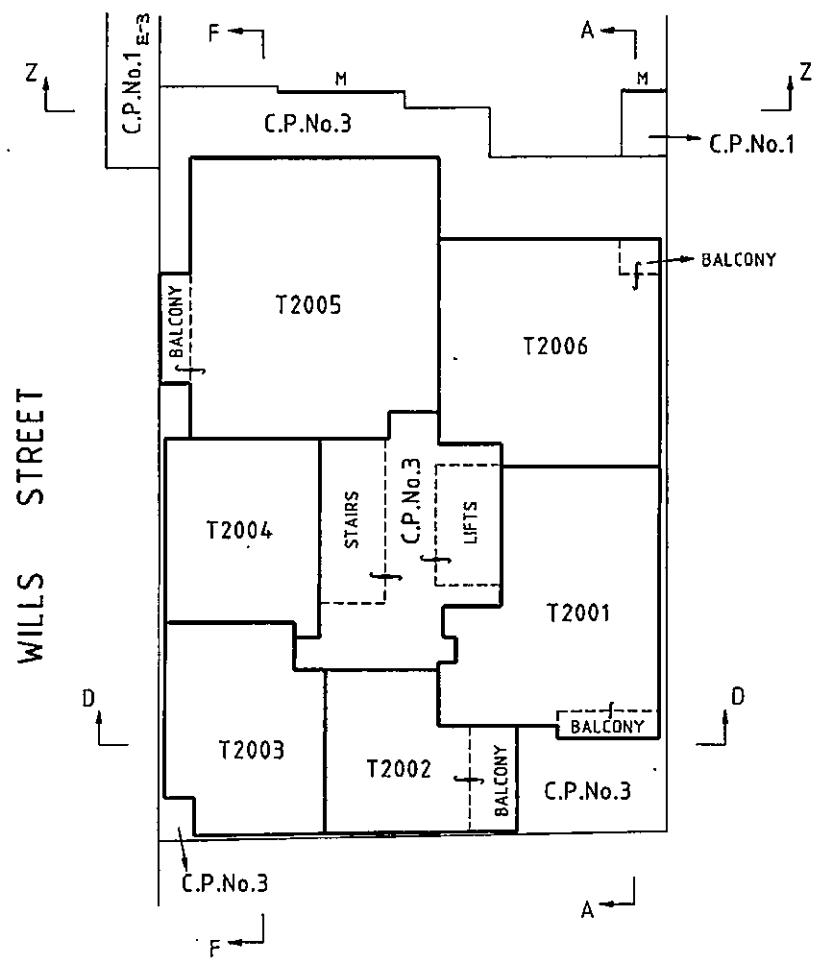
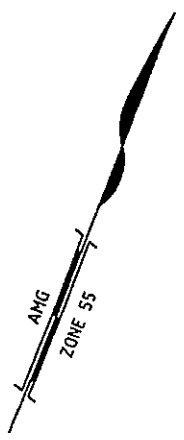

LEVEL TWENTY



BEVERIDGE WILLIAMS & CO. PTY.LTD.
 ACN 006 197 235 ABN 44 622 029 684
 SURVEYORS ENGINEERS PLANNERS
 ENVIRONMENTAL CONSULTANTS
 PO BOX 2205 CAULFIELD JUNCTION 3161 95284444
 PO BOX 1465 BALLARAT NAIL CENTRE 3354 53313877
 PO BOX 181 LEONGATHA 3953 58622630
 PO BOX 129 WENTHACCI 3995 56721505
 PO BOX 1916 TRARALGON 3844 51760374

ORIGINAL		SCALE	LICENSED SURVEYOR <u>JOHN FRANCIS WILLIAMS</u> (PRINT)	DATE <u>30/09/2002</u>	Sheet 18 of 67 Sheets
SCALE	SHEET SIZE	<p>LENGTHS ARE IN METRES</p>	SIGNATURE _____	DATE <u>30/09/2002</u>	DATE <u> / / </u>
1:200	A3		REF. <u>8455/2A</u> K:\DATA\8455\8455pss2.DGN	VERSION <u>2</u>	COUNCIL DELEGATE SIGNATURE _____ Original sheet size A3

PLAN OF SUBDIVISION

Stage No.

Plan Number

PS 444154U

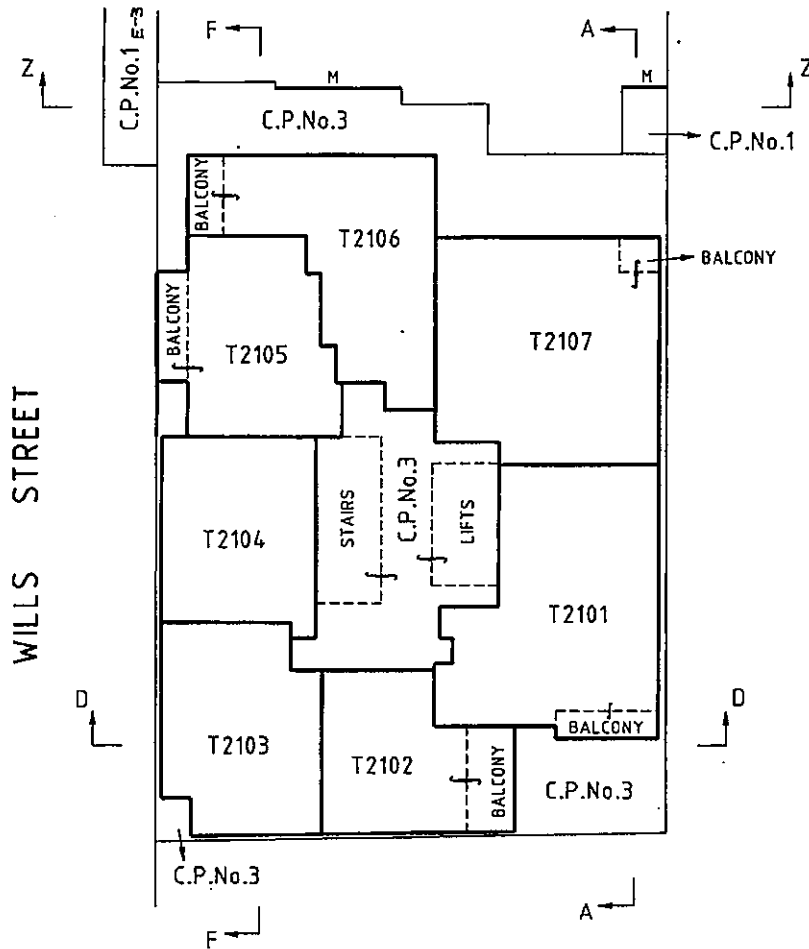
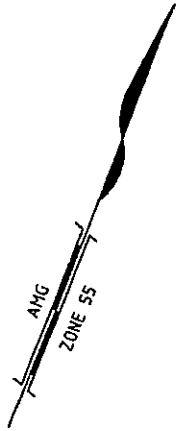

WILLS STREET

LEVEL TWENTY ONE



BEVERIDGE WILLIAMS & CO. PTY.LTD.
 ACN 006 197 235 ABN 44 622 029 694
 SURVEYORS ENGINEERS PLANNERS
 ENVIRONMENTAL CONSULTANTS
 PO BOX 2205 CAULFIELD JUNCTION 3161 95284444
 PO BOX 1465 BALLARAT MAIL CENTRE 3354 53313877
 PO BOX 161 LEDGATHA 3953 56622630
 PO BOX 129 WDNTHAGGI 3995 56721505
 PO BOX 1916 TRARALGON 3844 51760374

Sheet 19 of 67 Sheets

ORIGINAL
 SCALE
 1:200
 SHEET SIZE
 A3

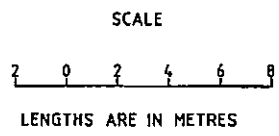

LICENSED SURVEYOR JOHN FRANCIS WILLIAMS
 (PRINT)
 SIGNATURE _____ DATE 30/09/2002
 REF. 8455/2A
 K:\DATA\8455\8455pss2.DGN VERSION 2

DATE / /
 COUNCIL DELEGATE SIGNATURE
 Original sheet size A3

PLAN OF SUBDIVISION	Stage No.	Plan Number PS 444154U
---------------------	-----------	----------------------------------

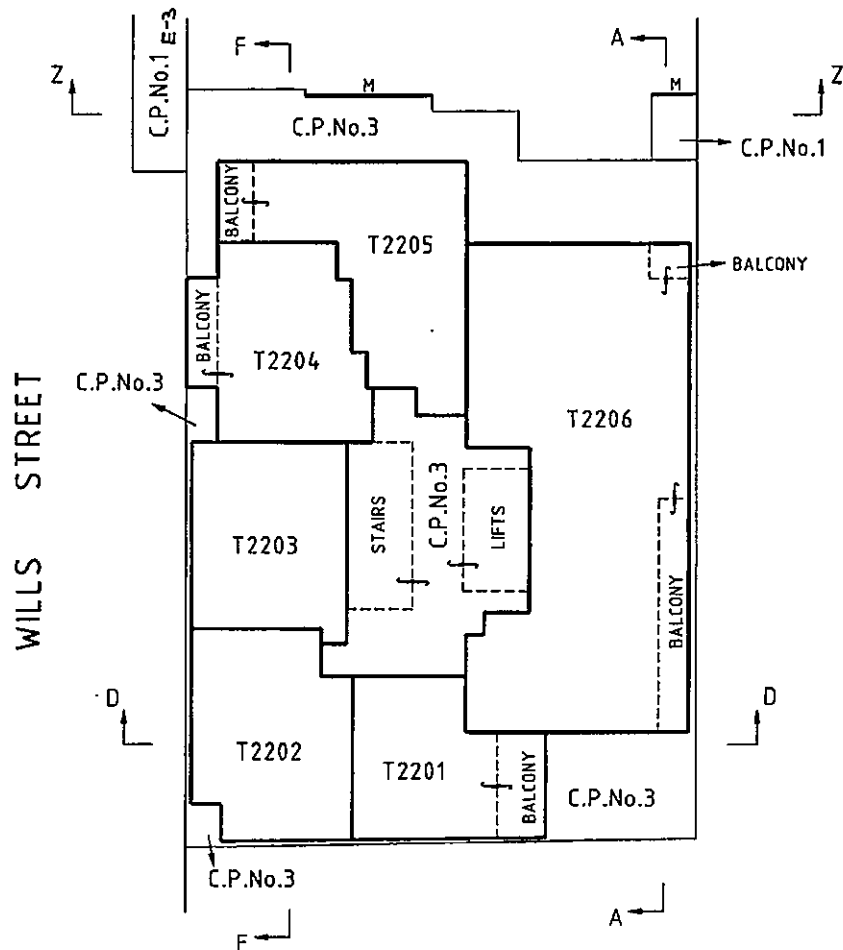
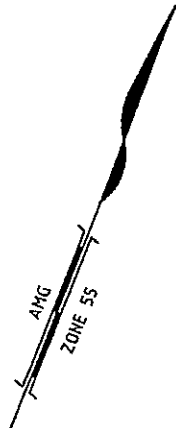

LEVEL TWENTY TWO



BEVERIDGE WILLIAMS & CO. PTY.LTD.
 ACN 008 187 235 ABN 44 622 029 694
 SURVEYORS . ENGINEERS . PLANNERS
 ENVIRONMENTAL CONSULTANTS
 PD BOX 2205 CAULFIELD JUNCTION 3161 95284444
 PD BOX 1465 BALLARAT MAIL CENTRE 3354 53313877
 PD BOX 161 LEONGATHA 3953 56622630
 PD BOX 129 WONTHAGGI 3995 56721505
 PD BOX 1916 TRARALGON 3844 51760374

Sheet 20 of 67 Sheets

ORIGINAL
SCALE
1 : 200
SHEET SIZE
A3

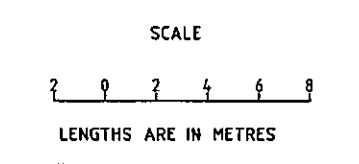

LICENSED SURVEYOR JOHN FRANCIS WILLIAMS
 (PRINT)

SIGNATURE _____ DATE 30/09/2002

REF. 8455/2A

K:\DATA\8455\8455pss2.DGN

VERSION 2

DATE / /

COUNCIL DELEGATE SIGNATURE

Original sheet size A3

PLAN OF SUBDIVISION

Stage No.

Plan Number

PS 444154U

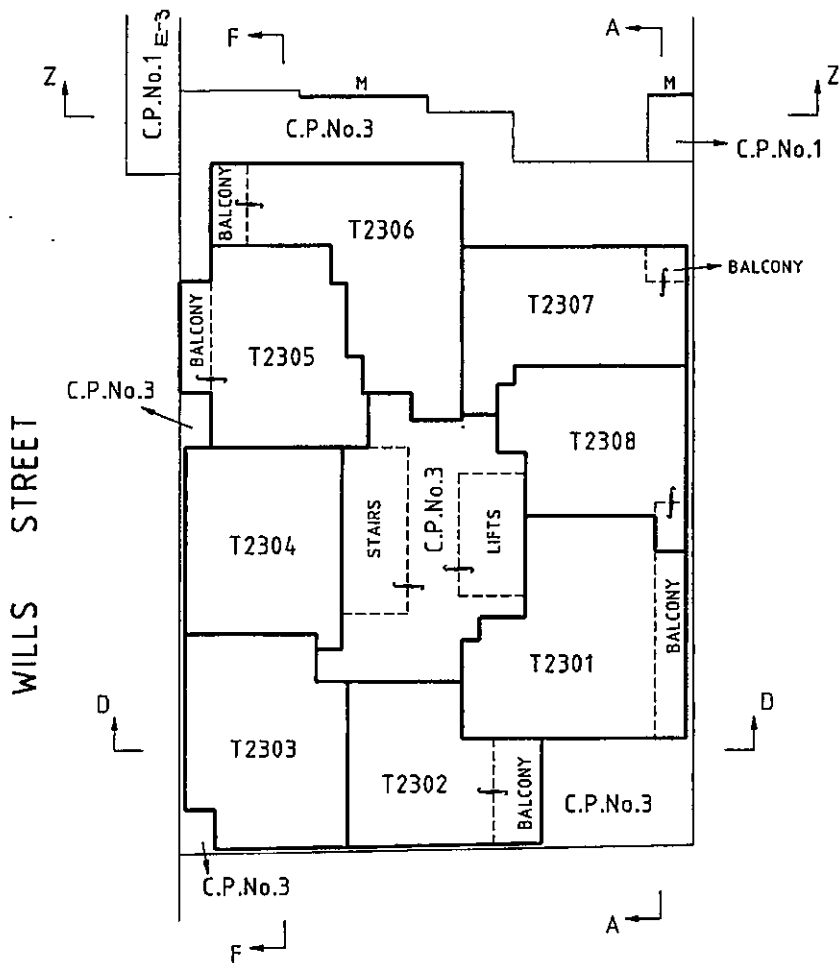
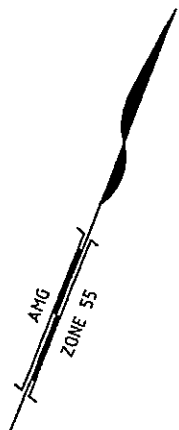

LEVEL TWENTY THREE



BEVERIDGE WILLIAMS & CO. PTY.LTD.
 ACN 006 197 235 ABN 44 622 029 694
SURVEYORS, ENGINEERS, PLANNERS
ENVIRONMENTAL CONSULTANTS
 PO BOX 2205 CAULFIELD JUNCTION 3161 95284444
 PO BOX 1465 BALLARAT MAIL CENTRE 3354 53313877
 PO BOX 161 LEONGATHA 3853 56622630
 PO BOX 129 WINTHACCI 3895 56721505
 PD BOX 1916 TRARALGON 3844 51760374

Sheet 21 of 67 Sheets

ORIGINAL
 SCALE SHEET SIZE
 1:200 A3

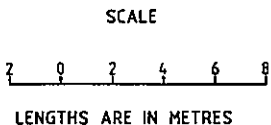

LICENSED SURVEYOR JOHN FRANCIS WILLIAMS
 (PRINT)

SIGNATURE _____ DATE 30/09/2002

REF. 8455/2A

K:\DATA\8455\8455pss2.DGN

VERSION 2

DATE / /

COUNCIL DELEGATE SIGNATURE

Original sheet size A3

PLAN OF SUBDIVISION	Stage No. -	Plan Number PS 444154U
---------------------	----------------	----------------------------------

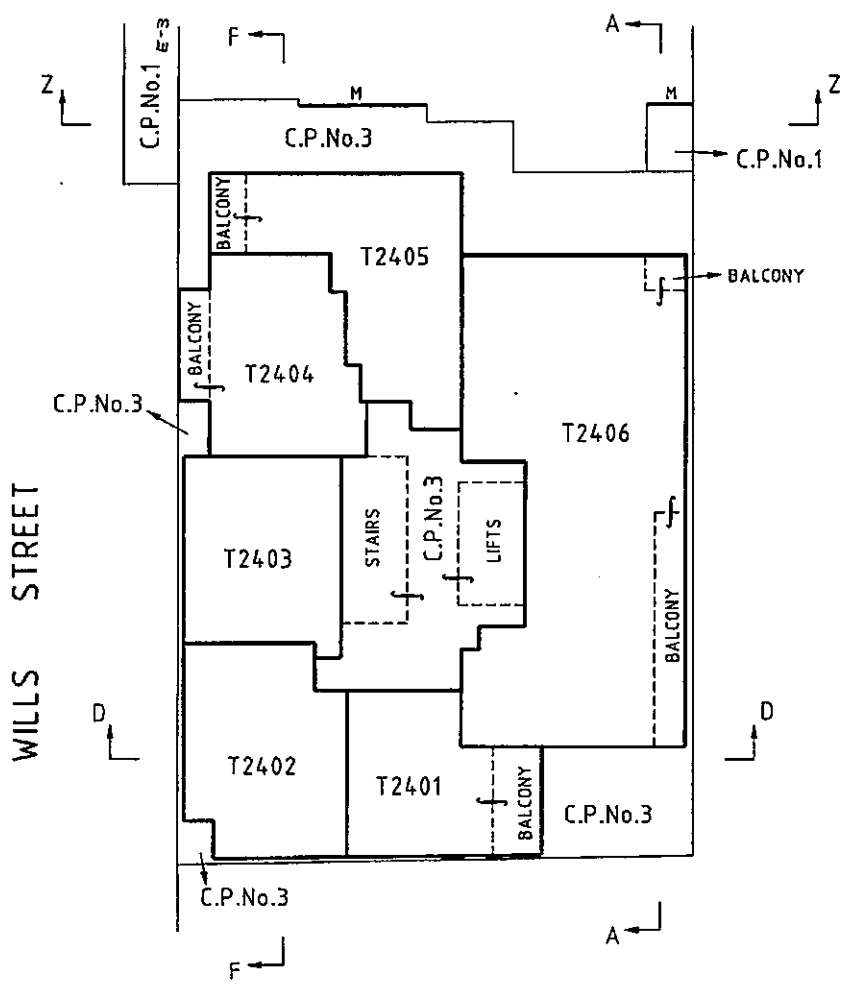
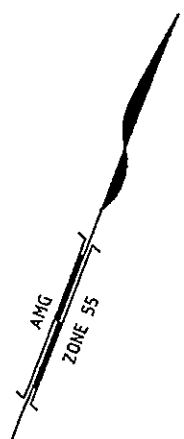

LEVEL TWENTY FOUR

BW BEVERIDGE WILLIAMS & CO. PTY.LTD.
 ACN 006 197 235 ABN 44 622 029 694
 SURVEYORS . ENGINEERS . PLANNERS
 ENVIRONMENTAL CONSULTANTS
 PD BOX 2205 CAULFIELD JUNCTION 3161 95284444
 PO BOX 1465 BALLARAT MAIL CENTRE 3354 53313877
 PO BOX 161 LEONGATHA 3953 56622630
 PO BOX 123 WUNTHACCI 3995 56721505
 PO BOX 1915 TRARALGON 3844 51760374

ORIGINAL SCALE 1 : 200	SHEET SIZE A3	SCALE LENGTHS ARE IN METRES	LICENSED SURVEYOR <u>JOHN FRANCIS WILLIAMS</u> (PRINT) SIGNATURE _____ DATE 30/09/2002 REF. 8455/2A K:\DATA\8455\8455pss2.DGN	Sheet 22 of 67 Sheets DATE / / COUNCIL DELEGATE SIGNATURE Original sheet size A3
--------------------------------------	----------------------	--	---	---

PLAN OF SUBDIVISION	Stage No.	Plan Number PS 444154U
----------------------------	-----------	----------------------------------

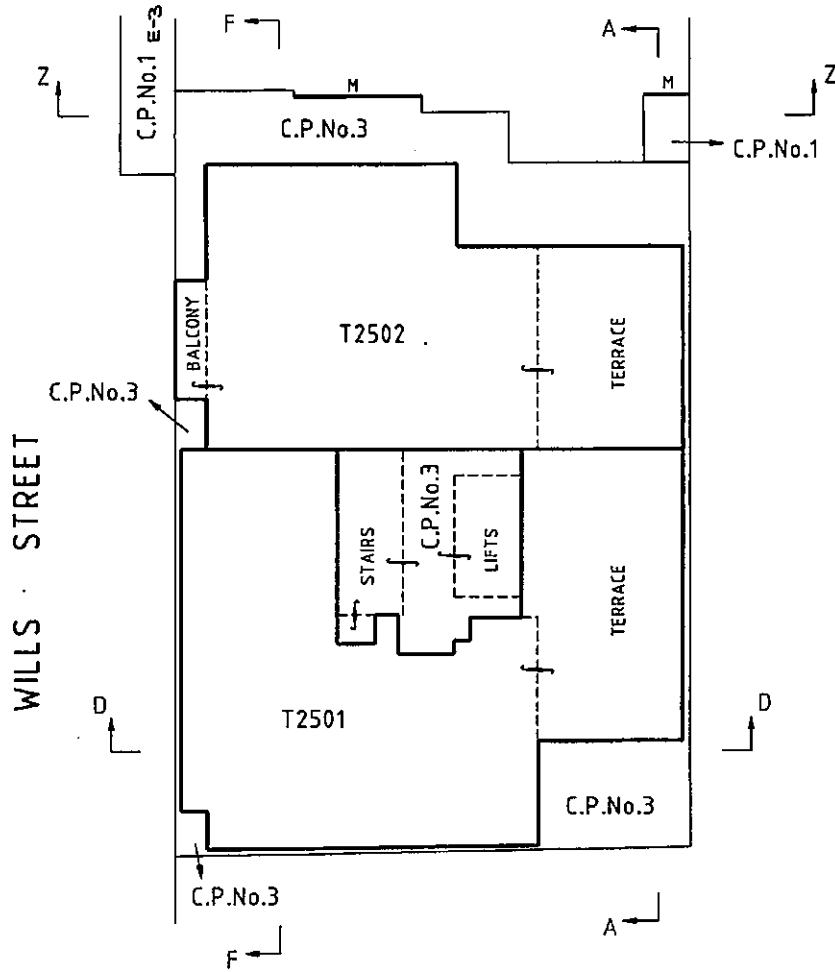
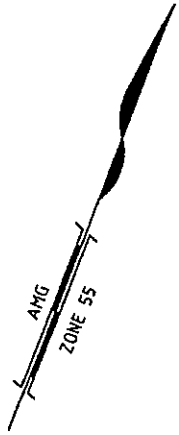

LEVEL TWENTY FIVE



BEVERIDGE WILLIAMS & CO. PTY.LTD.
 ACN 006 197 235 ABN 44 622 029 694
 SURVEYORS . ENGINEERS . PLANNERS
 ENVIRONMENTAL CONSULTANTS
 PO BOX 2205 CAULFIELD JUNCTION 3161 95284444
 PO BOX 1465 BALLARAT MAIL CENTRE 3354 53313877
 PO BOX 161 LEONGATHA 3953 56522630
 PO BOX 129 WDNTHAGGI 3995 56721505
 PO BOX 1916 TRARALGON 3844 51760374

Sheet 23 of 67 Sheets

ORIGINAL		LICENSED SURVEYOR <u>JOHN FRANCIS WILLIAMS</u> (PRINT)	
SCALE	SHEET SIZE	SIGNATURE _____	DATE 30/09/2002
1:200	A3	REF. 8455/2A	DATE / /
	<p style="text-align: center;">LENGTHS ARE IN METRES</p>	K:\DATA\8455\8455pss2.DGN	VERSION 2
			COUNCIL DELEGATE SIGNATURE _____
			Original sheet size A3

PLAN OF SUBDIVISION	Stage No.	Plan Number PS 444154U
---------------------	-----------	----------------------------------

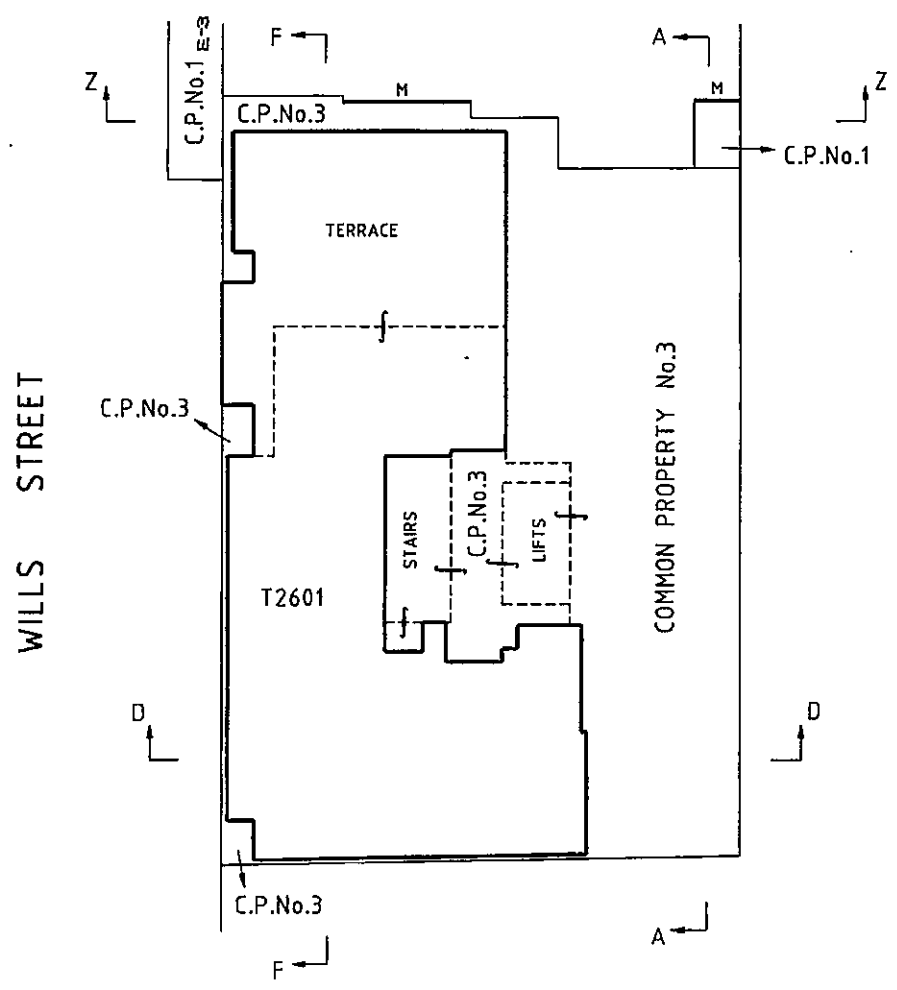
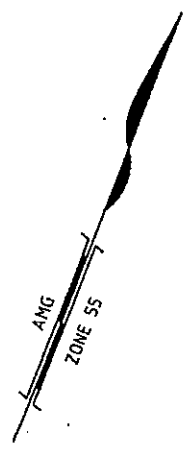

LEVEL TWENTY SIX

BW BEVERIDGE WILLIAMS & CO. PTY.LTD.
 ACN 006 197 235 ABN 44 622 029 694
 SURVEYORS, ENGINEERS, PLANNERS
 ENVIRONMENTAL CONSULTANTS
 PD BDX 2205 CAULFIELD JUNCTION 3161 95284444
 PO BOX 1485 BALLARAT MAIL CENTRE 3354 53313877
 PD BOX 161 LEDGATHA 3953 56622630
 PD BOX 129 WONTHAGGI 3995 56721505
 PD BOX 1916 TRARALGON 3844 51760374

Sheet 24 of 67 Sheets

DATE / /

COUNCIL DELEGATE SIGNATURE

Original sheet size A3

ORIGINAL		SCALE	LICENSED SURVEYOR <u>JOHN FRANCIS WILLIAMS</u> (PRINT)
SCALE	SHEET SIZE	<p>LENGTHS ARE IN METRES</p>	SIGNATURE _____ DATE 30/09/2002
1:200	A3		REF. 8455/2A K:\DATA\8455\8455pss2.DGN

VERSION 2

PLAN OF SUBDIVISION	Stage No.	Plan Number PS 444154U
----------------------------	-----------	----------------------------------

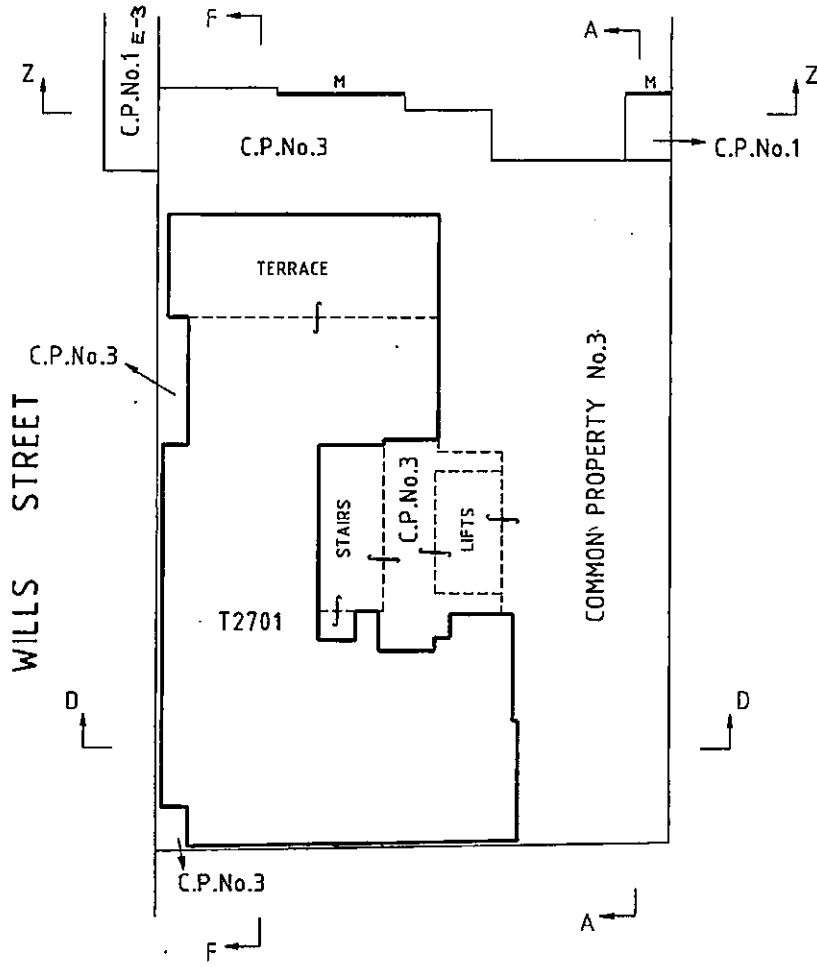
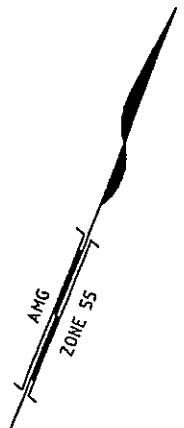

LEVEL TWENTY SEVEN

BW REVERIDGE WILLIAMS & CO. PTY.LTD.
 ACN 006 197 235 ABN 44 522 029 694
 SURVEYORS, ENGINEERS, PLANNERS
 ENVIRONMENTAL CONSULTANTS
 PO BOX 2205 CAULFIELD JUNCTION 3161 95284444
 PO BOX 1465 BALLARAT MAIL CENTRE 3354 53513877
 PO BOX 161 LEONGATHA 3953 56622630
 PO BOX 129 WINTHAGGI 3995 56721505
 PO BOX 1916 TRARALGON 3844 51760374

Sheet 25 of 67 Sheets
DATE / /
COUNCIL DELEGATE SIGNATURE
Original sheet size A3

ORIGINAL	SCALE	LICENSED SURVEYOR <u>JOHN FRANCIS WILLIAMS</u> (PRINT)	DATE 30/09/2002
SCALE		SIGNATURE _____	DATE 30/09/2002
1:200	LENGTHS ARE IN METRES	REF. 8455/2A	VERSION 2
SHEET SIZE		K:\DATA\8455\8455pss2.DGN	
A3			

PLAN OF SUBDIVISION	Stage No.	Plan Number PS 444154U
----------------------------	-----------	----------------------------------

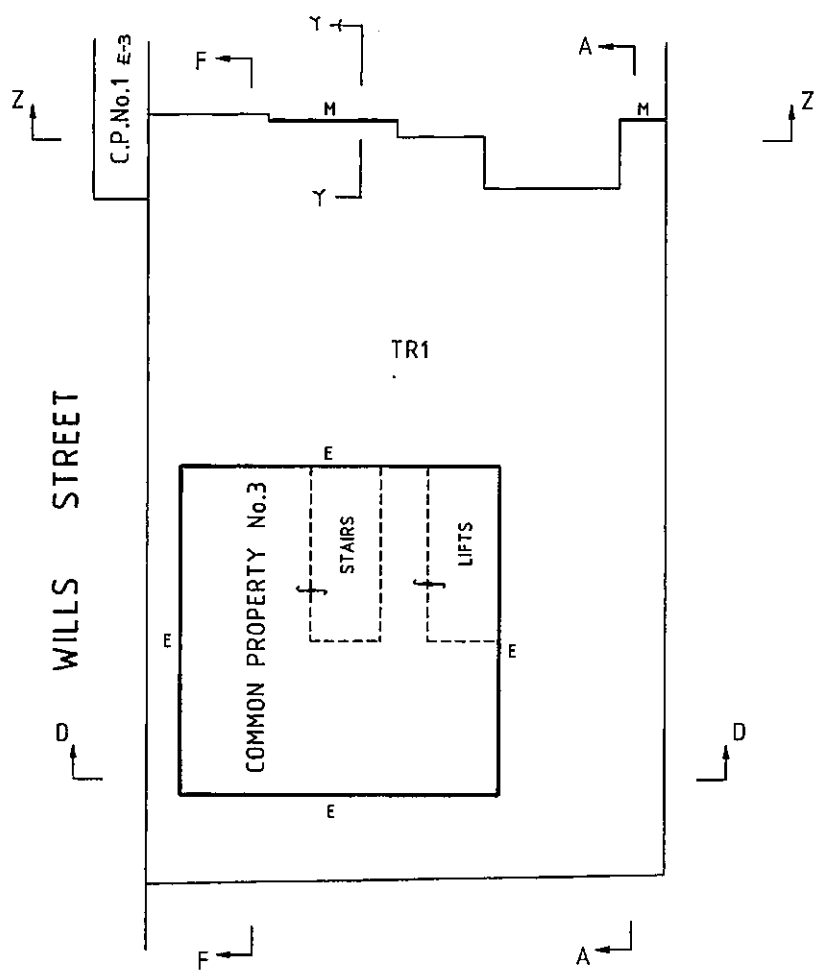
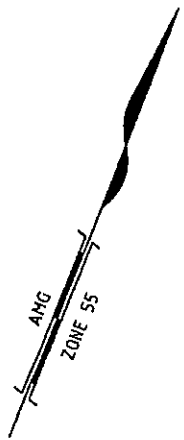

ROOF LEVEL

BW BEVERIDGE WILLIAMS & CO. PTY.LTD.
 ACN 006 197 235 ABN 44 622 029 694
 SURVEYORS, ENGINEERS, PLANNERS
 ENVIRONMENTAL CONSULTANTS
 PO BOX 2205 CAULFIELD JUNCTION 3161 95284444
 PO BOX 1465 BALLARAT MAIL CENTRE 3354 53313877
 PO BOX 161 LEONGATHA 3953 56622630
 PO BOX 129 WONTHAGGI 3995 56721505
 PO BOX 1916 TRARALGON 3844 51760374

ORIGINAL
 SCALE 1:200
 SHEET SIZE A3

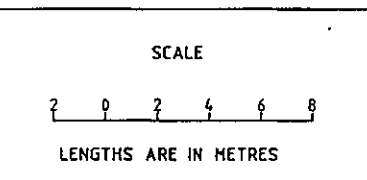

LICENSED SURVEYOR JOHN FRANCIS WILLIAMS
 (PRINT)
 SIGNATURE DATE 30/09/2002
 REF. 8455/2A
 K:\DATA\8455\8455pss2.DGN VERSION 2

Sheet 26 of 67 Sheets

DATE / /
 COUNCIL DELEGATE SIGNATURE
 Original sheet size A3

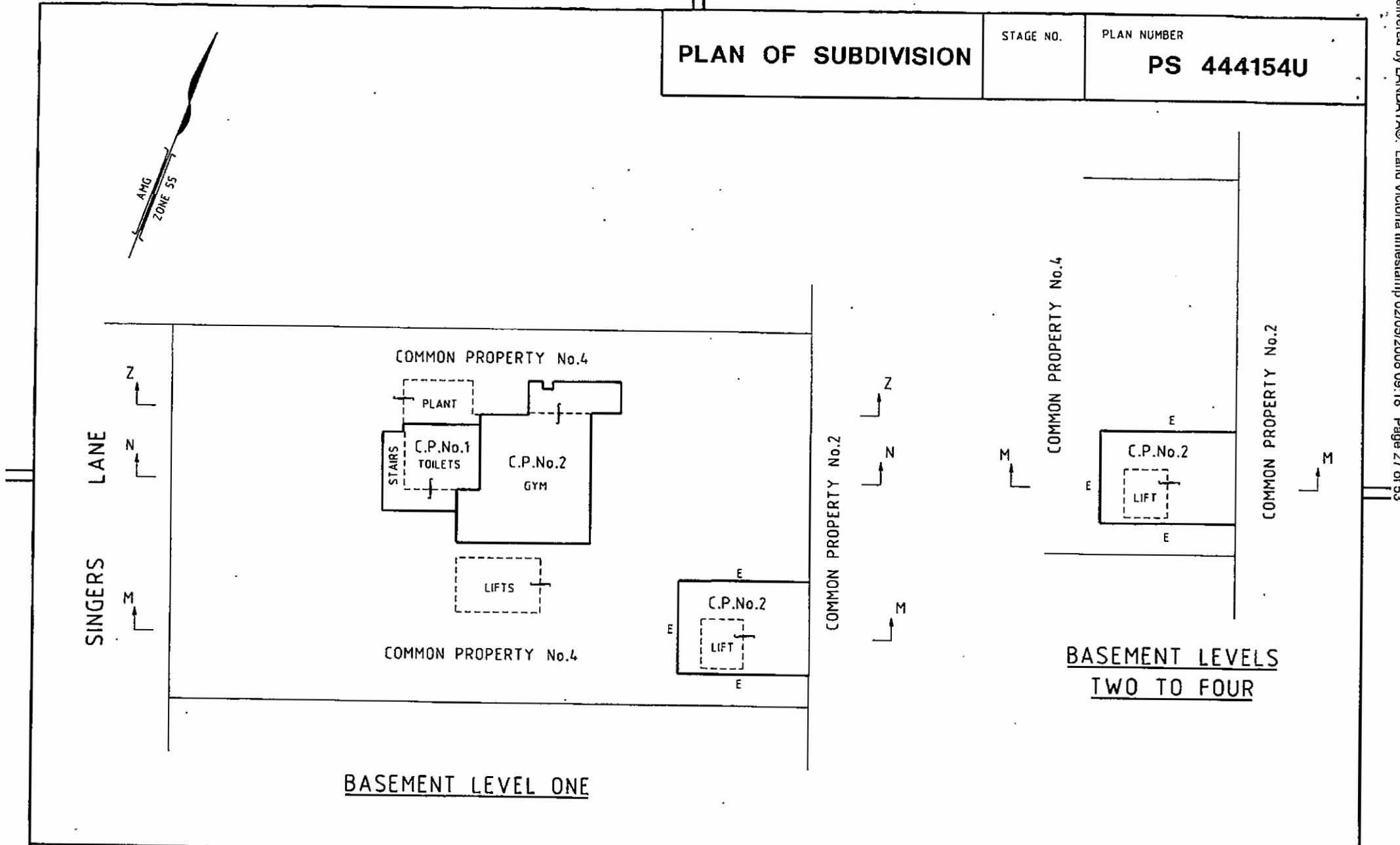
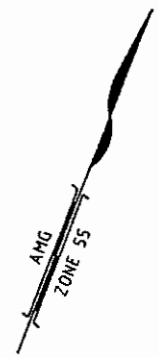

BASEMENT LEVEL ONE



ACN 006 197 235 ABN 44 622 029 694
SURVEYORS, ENGINEERS, PLANNERS
ENVIRONMENTAL CONSULTANTS
 PO BOX 2205 CAULFIELD JUNCTION 3161 95284444
 PO BOX 1465 BALLARAT MAIL CENTRE 3354 53313877
 PO BOX 161 LEONGATHA 3953 56622630
 PO BOX 129 WONTHAGGI 3995 56721505
 PO BOX 1916 TRARALGON 3844 51760374

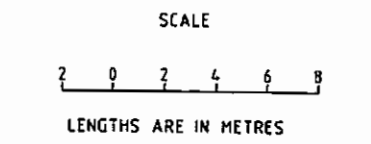

ORIGINAL
SCALE SHEET
1:200 A3

LICENSED SURVEYOR (PRINT) JOHN FRANCIS WILLIAMS	DATE 17/11/2003
SIGNATURE _____	REF. 8455/3
K:\DATA\8455\8455pss3.DGN	
VERSION 3	

Sheet 27 of 67 Sheets

 DATE / /
 COUNCIL DELEGATE SIGNATURE

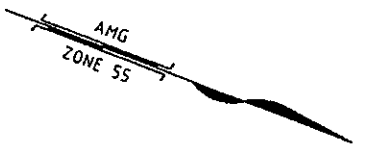

PLAN OF SUBDIVISION

STAGE NO.

PLAN NUMBER
PS 444154U

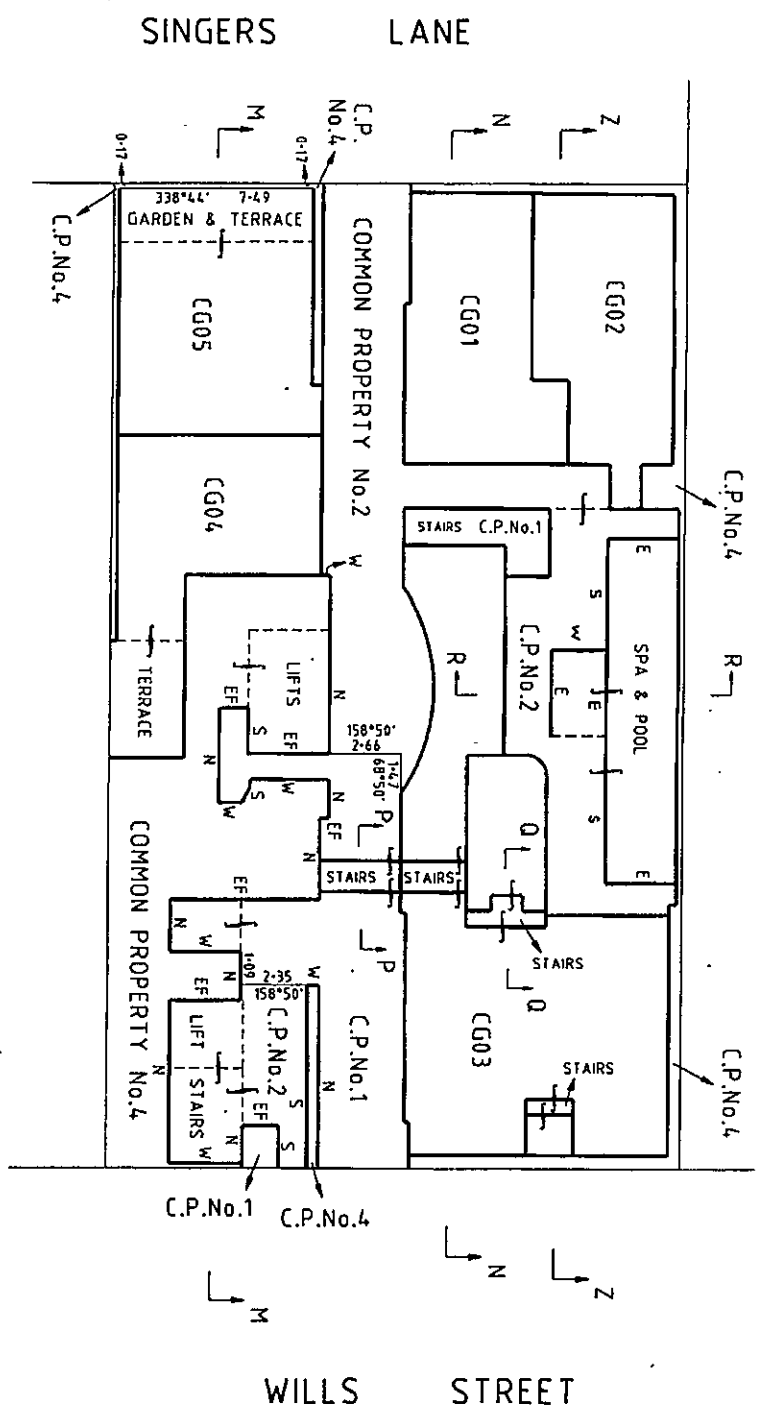

GROUND FLOOR

BM

ACN 006 197 235
SURVEYORS, ENGINEERS, PLANNERS
ENVIRONMENTAL CONSULTANTS
PO BOX 2205 CAULFIELD JUNCTION 3161 95284444
PO BOX 1465 BALLARAT MAIL CENTRE 3354 5313877
PO BOX 161 LEONGATHA 3953 56622630
PO BOX 129 MONTAGNA 3995 56721505
PO BOX 1916 TRARALGON 3844 51760174

ABN 44 622 029 694

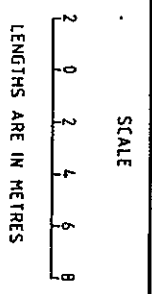

ORIGINAL SCALE 1:200
SHEET SIZE A3

LICENSED SURVEYOR (PRINT)
JOHN FRANCIS WILLIAMS

SIGNATURE REF. 8455/3 DATE 17/11/2003

K:\DATA\8455\8455ps3.DGN VERSION 3

Sheet 28 of 67 Sheets

DATE / /
COUNCIL DELEGATE SIGNATURE

PLAN OF SUBDIVISION

STAGE NO.

PLAN NUMBER

PS 444154U

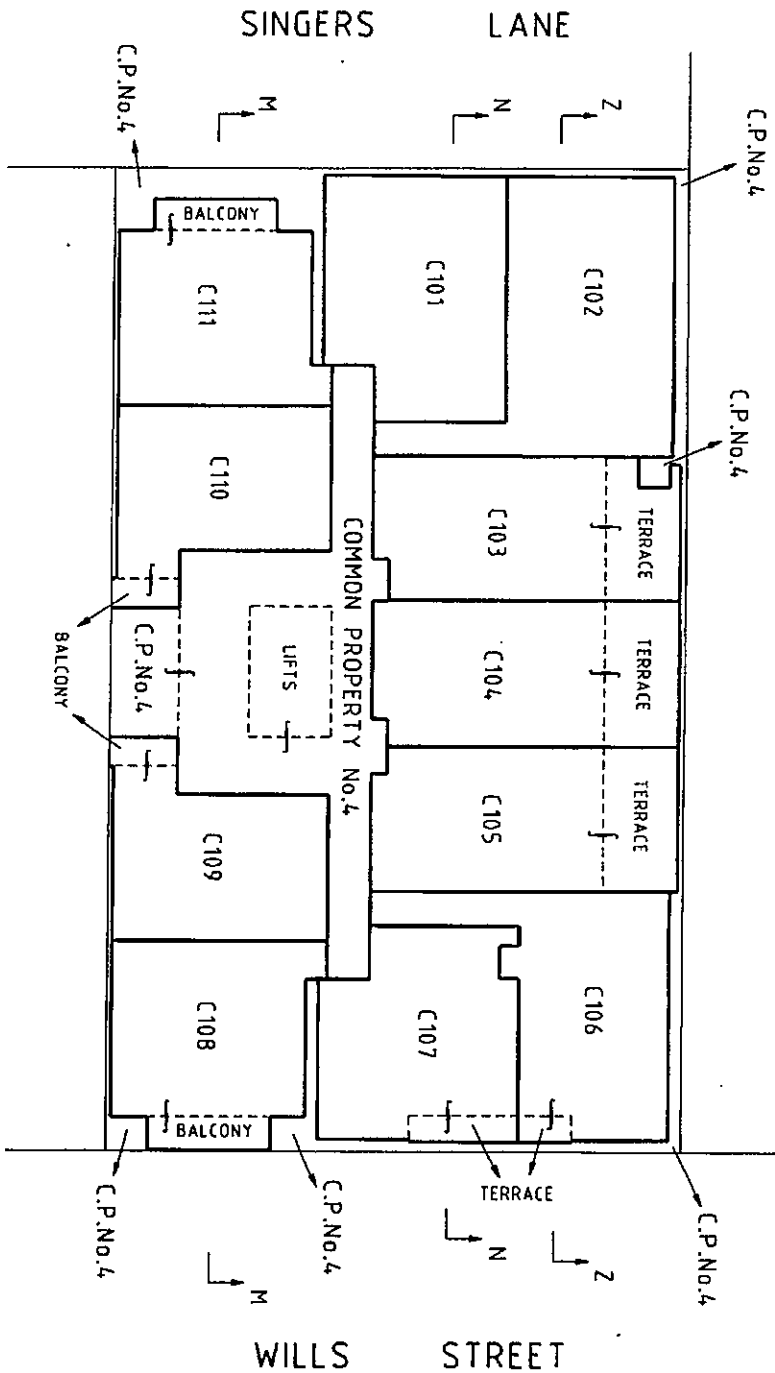
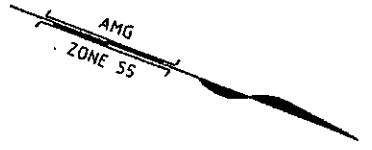

LEVEL ONE



ACH 006 197 235 ABN 44 622 029 694
 SURVEYORS, ENGINEERS, PLANNERS
 ENVIRONMENTAL CONSULTANTS
 PO BOX 2205 CAULFIELD JUNCTION 3161 95284444
 PO BOX 1465 BALLARAT MAIL CENTRE 3354 5313871
 PO BOX 161 LEONGATHA 3953 56622630
 PO BOX 129 MONTKAGI 3995 58721505
 PO BOX 1916 TRARLIGNON 3844 51760314

SCALE
 2 0 2 4 6 8
 LENGTHS ARE IN METRES

ORIGINAL SCALE 1:200
 SHEET SIZE A3

LICENSED SURVEYOR JOHN FRANCIS WILLIAMS
 SIGNATURE REF: 8455/3 DATE 17/11/2003
 K:\DATA\8455\8455PS3.DGN VERSION 3

Sheet 29 of 67 Sheets
 DATE / /
 COUNCIL DELEGATE SIGNATURE

PLAN OF SUBDIVISION

STAGE NO.

PLAN NUMBER
PS 444154U

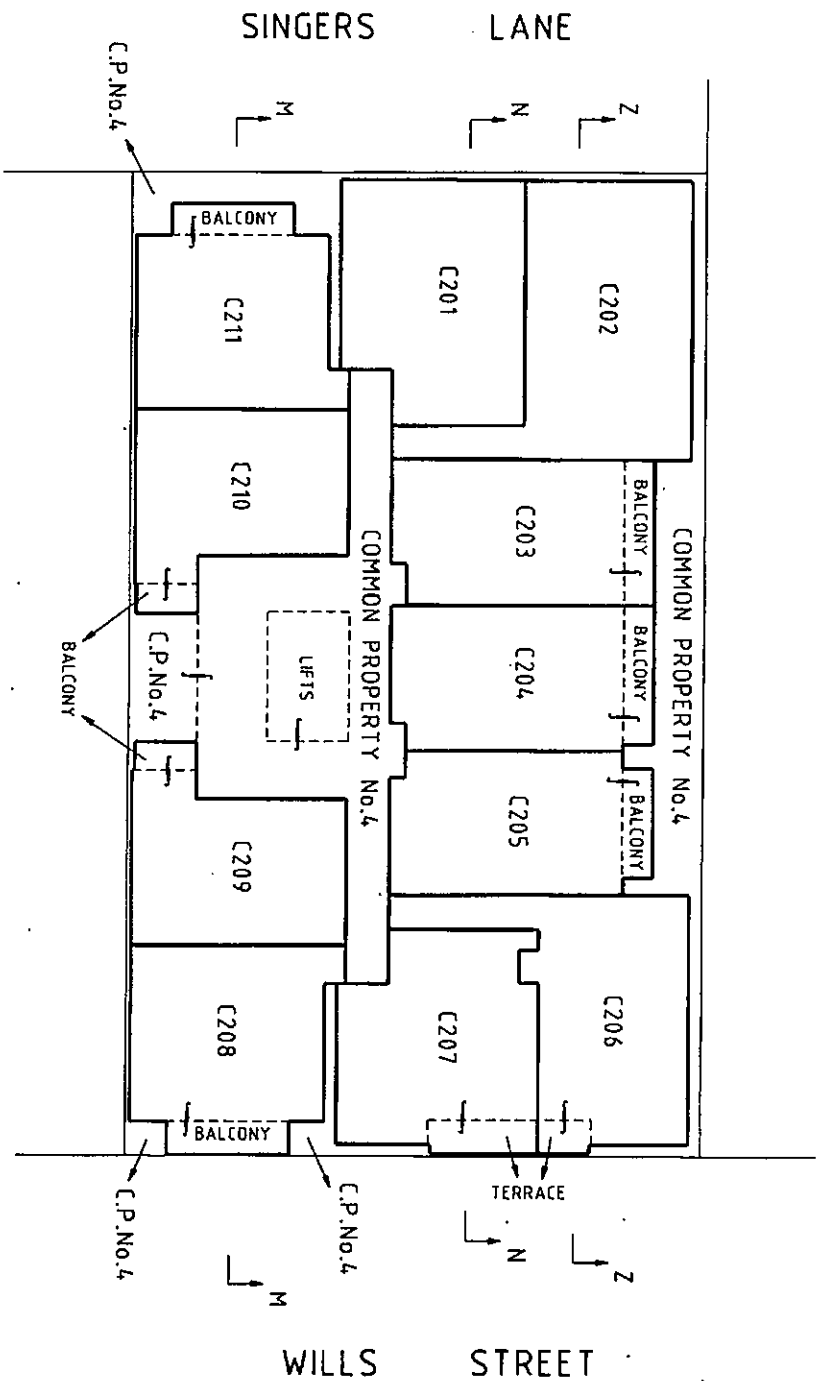
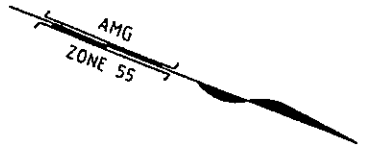

LEVEL TWO



ACN 006 197 235 ABN 44 622 029 694
 SURVEYORS, ENGINEERS & PLANNERS
 ENVIRONMENTAL CONSULTANTS
 PO BOX 2205 CAULFIELD JUNCTION 3161 95284444
 PO BOX 1195 BALLARAT MALE CENTRE 3354 53313871
 PO BOX 161 LEONGATHA 3553 56622630
 PO BOX 129 MONTAGGI 3595 56721505
 PO BOX 1916 TRARALGON 3844 51760374

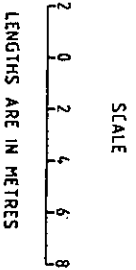

ORIGINAL SCALE 1:200
 SHEET SIZE A3

LICENSED SURVEYOR JOHN FRANCIS WILLIAMS
 (PRINT)
 SIGNATURE
 REF: 8455/3
 K:\DATA\8455\8455PSS3.DGN
 DATE 17/11/2003
 VERSION 3

Sheet 30 of 67 Sheets
 DATE / /
 COUNCIL DELEGATE SIGNATURE

PLAN OF SUBDIVISION

STAGE NO.

PLAN NUMBER

PS 444154U

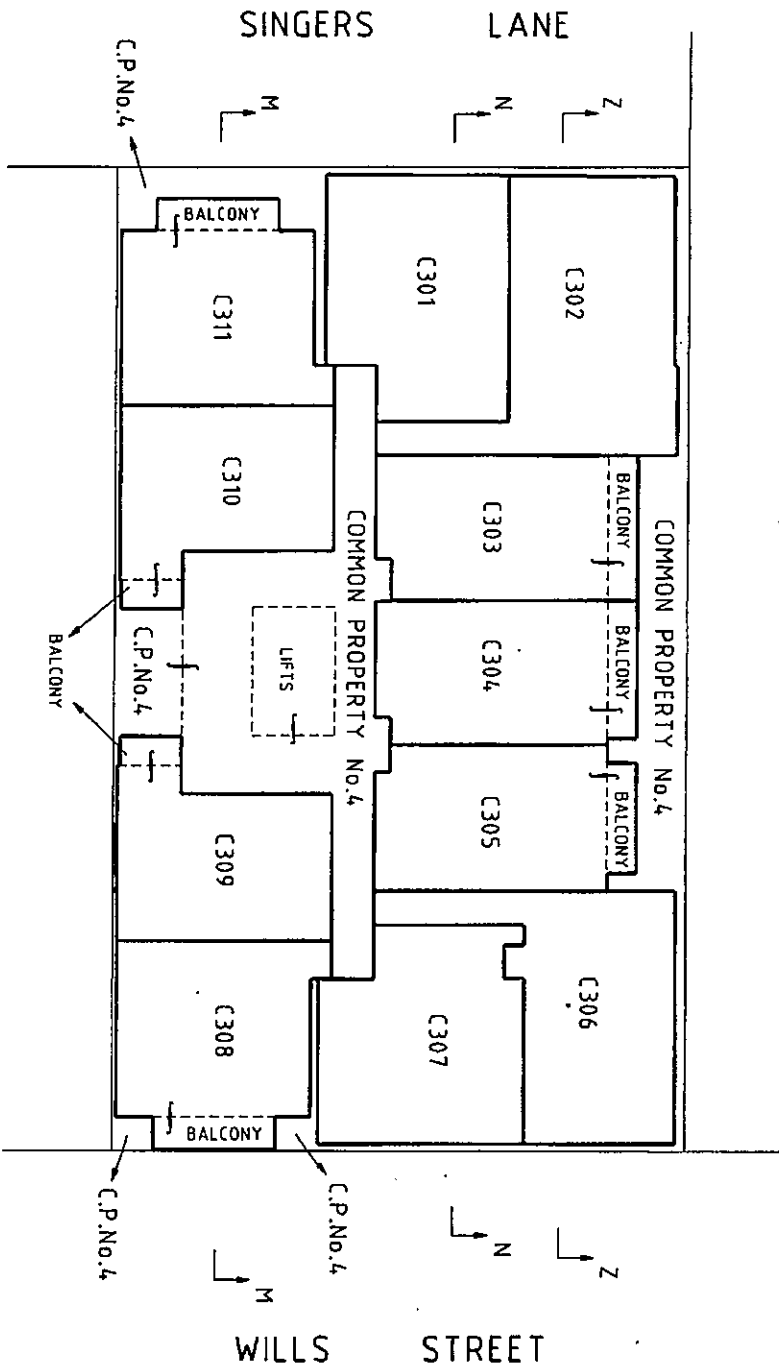
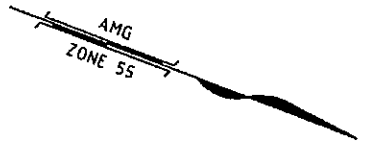

LEVEL THREE

BW
 ACN 006 197 235 ABR 44 622 029 694
 SURVEYORS, ENGINEERS, PLANNERS
 ENVIRONMENTAL CONSULTANTS
 PO BOX 2209 CAULFIELD JUNCTION 3161 95284444
 PO BOX 165 BALLARAT MAIL CENTRE 3354 53313877
 PO BOX 161 LEONGATHA 3955 56622630
 PO BOX 129 MONTAGOLI 3995 56721505
 PO BOX 1916 TRARALGON 3844 51760374

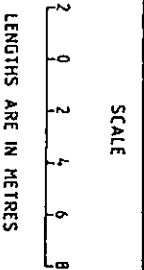

ORIGINAL SCALE 1:200
 SHEET SIZE A3

LICENSED SURVEYOR (PRINT)
 JOHN FRANCIS WILLIAMS
 REF: 8455/3
 DATE 17/11/2003
 VERSION 3

Sheet 31 of 67 Sheets
 DATE / /
 COUNCIL DELEGATE SIGNATURE

PLAN OF SUBDIVISION

STAGE NO.

PLAN NUMBER

PS 444154U

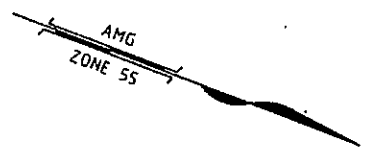

SINGERS LANE

WILLS STREET

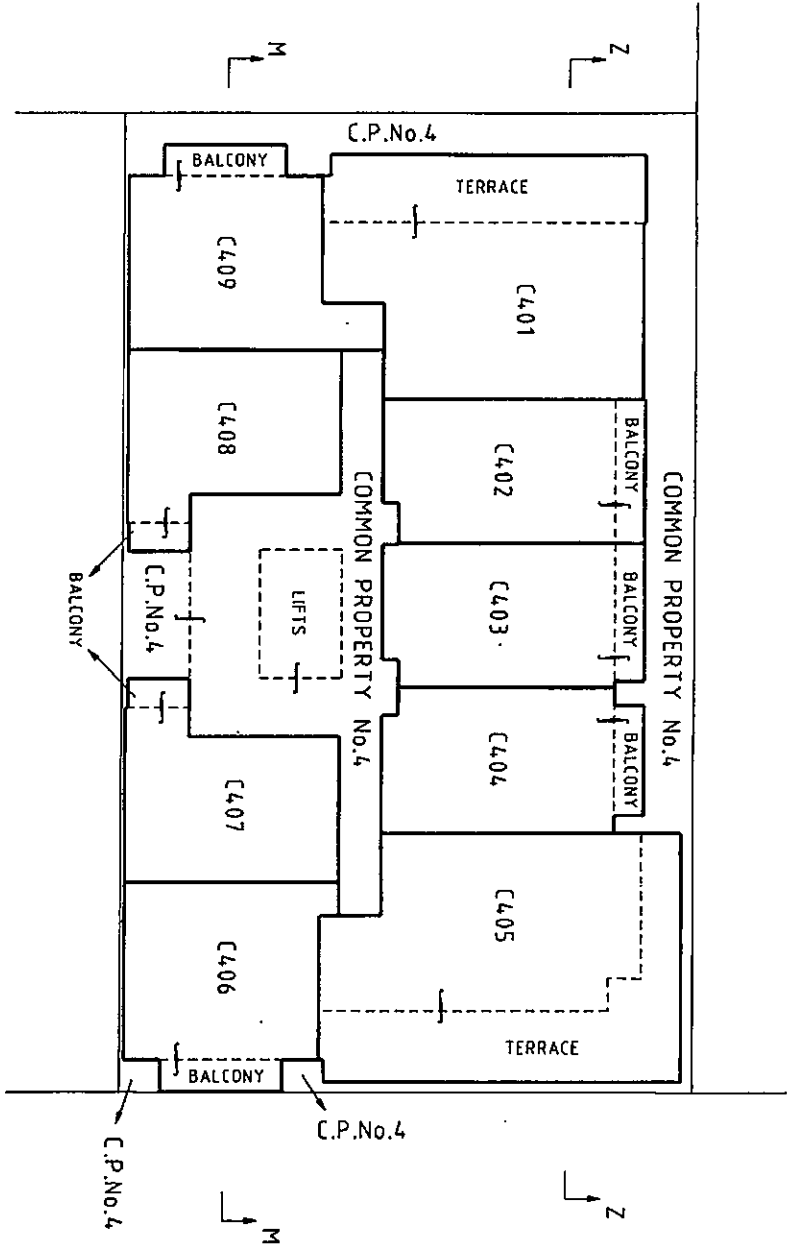

LEVEL FOUR



ACN 006 197 235 ABN 44 622 029 694
 SURVEYORS, ENGINEERS, PLANNERS
 ENVIRONMENTAL CONSULTANTS
 PO BOX 2205 CAULFIELD JUNCTION 3161 95284444
 PO BOX 465 BALLARAT MAIL CENTRE 3354 53138777
 PO BOX 161 LEONGATHA 3953 56622500
 PO BOX 128 MONTAGUT 3995 56721505
 PO BOX 1316 TRARALGON 3844 51760374

SCALE



LENGTHS ARE IN METRES

ORIGINAL

SCALE

1:200

SHEET

SIZE

A3

LICENSED SURVEYOR

JOHN FRANCIS WILLIAMS

(PRINT)

SIGNATURE

REF. 8455/3

DATE 17/11/2003

K:\DATA\8455\8455ps53.DGN

VERSION 3

Sheet 32 of 67 Sheets

DATE / /

COUNCIL DELEGATE SIGNATURE

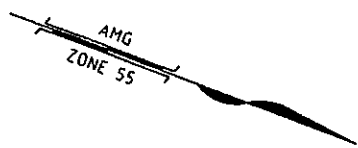

SINGERS LANE

WILLS STREET

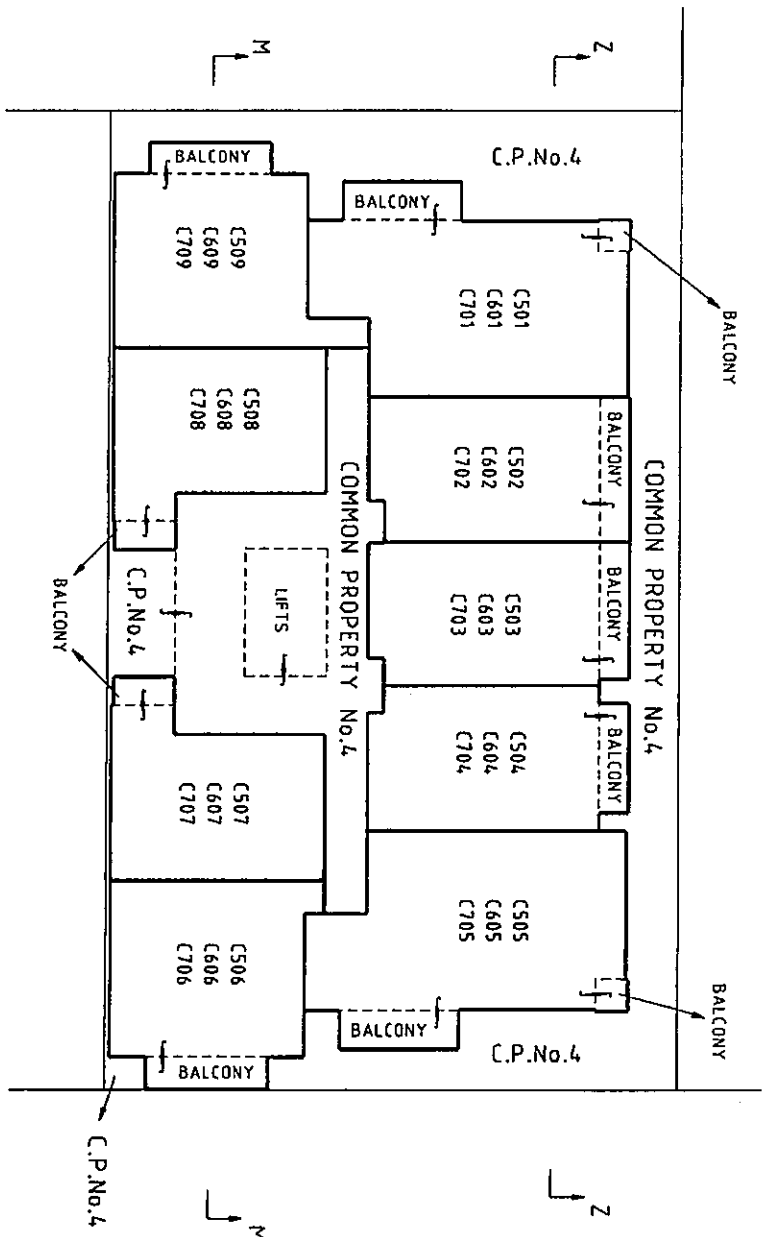

LEVELS FIVE TO SEVEN

PLAN OF SUBDIVISION

STAGE NO.

PLAN NUMBER

PS 444154U



ACN 006 197 235 ABN 44 622 029 694
 SURVEYORS, ENGINEERS, PLANNERS
 ENVIRONMENTAL CONSULTANTS
 PG BOX 2205 CAULFIELD JUNCTION 3161 95284444
 PG BOX 165 BALLARAT MAIL CENTRE 3394 53138877
 PG BOX 161 LEONORA 3953 56822610
 PG BOX 129 MORTHAGE 3993 56721005
 PG BOX 1918 TRARALGON 3844 51780374

SCALE

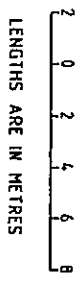

ORIGINAL

SCALE

1:200

SHEET

A3

LICENSED SURVEYOR (PRINT)

JOHN FRANCIS WILLIAMS

SIGNATURE

REF. 8455/3

DATE

17/11/2003

Sheet 33 of 67 Sheets

DATE / /

COUNCIL DELEGATE SIGNATURE

PLAN OF SUBDIVISION

STAGE NO.

PLAN NUMBER
PS 444154U

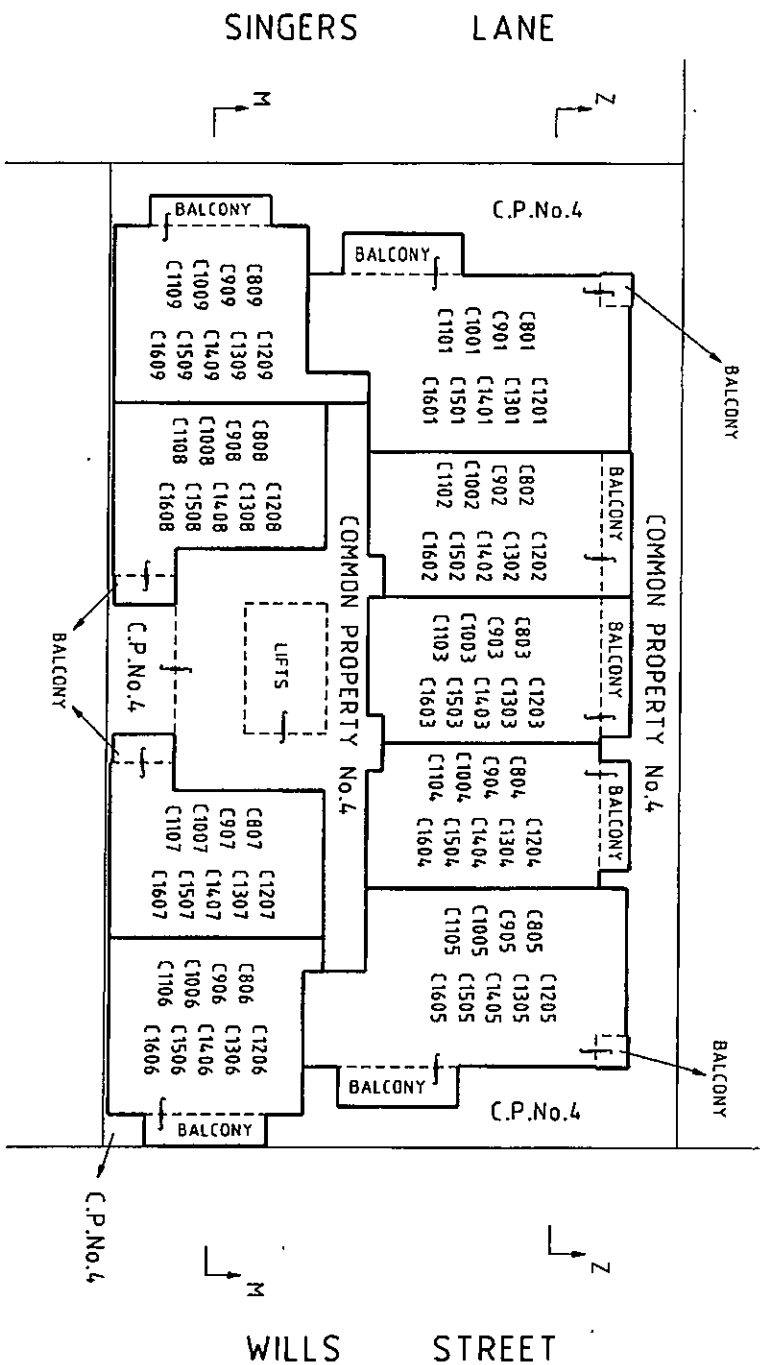
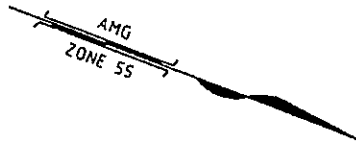

LEVELS EIGHT TO SIXTEEN



ACN 006 197 235 ABN 44 622 029 694
 SURVEYORS, ENGINEERS, PLANNERS,
 ENVIRONMENTAL CONSULTANTS
 PO BOX 2205 CAULFIELD JUNCTION 3161 95284444
 PO BOX 1465 BALLARAT MAIL CENTRE 3354 53313877
 PO BOX 161 LEONGATHA 3953 56622630
 PO BOX 129 MONTAGGI 3995 56721505
 PO BOX 1916 TRARALGON 3844 51760374

SCALE

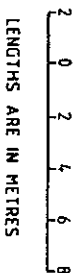

ORIGINAL SCALE

1 : 200
 SHEET SIZE
 A3

LICENSED SUPERVISOR
 (PRINT)

JOHN FRANCIS WILLIAMS

SIGNATURE

REF. 8455/3

DATE 17/11/2003

K:\DATA\8455\8455ps3.DGN

VERSION 3

Sheet 34 of 67 Sheets

DATE / /
 COUNCIL DELEGATE SIGNATURE

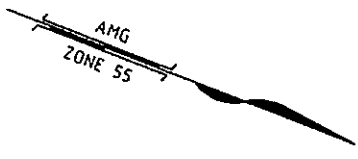

PLAN OF SUBDIVISION	STAGE NO.	PLAN NUMBER
		PS 444154U

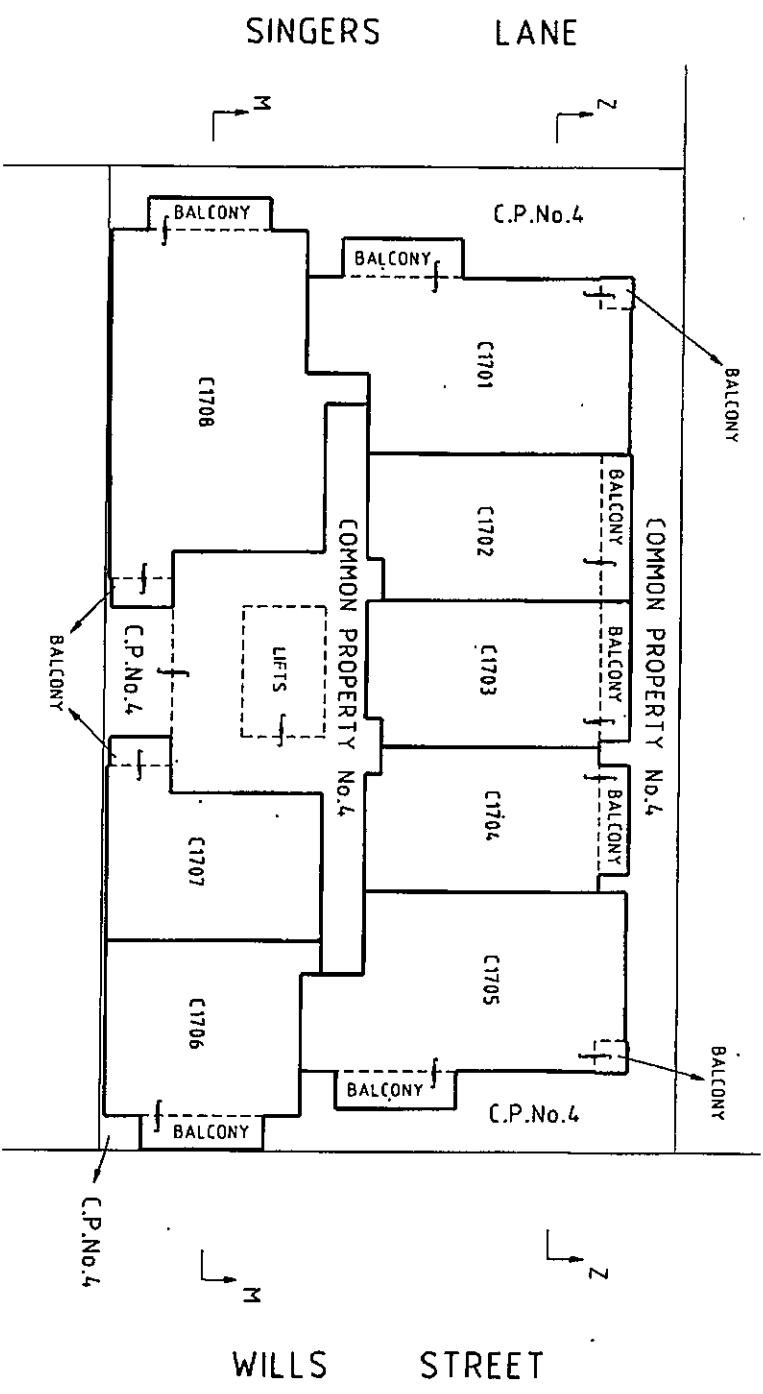

BW

ACN 006 197 235 ABN 44 622 029 694
 SURVEYORS, ENGINEERS, PLANNERS
 ENVIRONMENTAL CONSULTANTS
 PO BOX 2205 CALLEFIELD JUNCTION 3161 95284444
 PO BOX 162 BALLARAT MAIL CENTRE 3594 5313877
 PO BOX 161 LEONGATHA 3953 56622630
 PO BOX 128 MONTAGOMI 3995 56721505
 PO BOX 1916 TRARALGON 3844 51760374

SCALE

2 0 2 4 6 8

LENGTHS ARE IN METRES

ORIGINAL SCALE 1:200

SHEET SIZE A3

LICENSED SURVEYOR (P/HRM) JOHN FRANCIS WILLIAMS

SIGNATURE REF: 8455/3 DATE 17/11/2003

K:\DATA\8455\8455ps3.DGN VERSION 3

Sheet 36 of 67 Sheets

DATE / / COUNCIL DELEGATE SIGNATURE

PLAN OF SUBDIVISION

STAGE NO.

PLAN NUMBER

PS 444154U

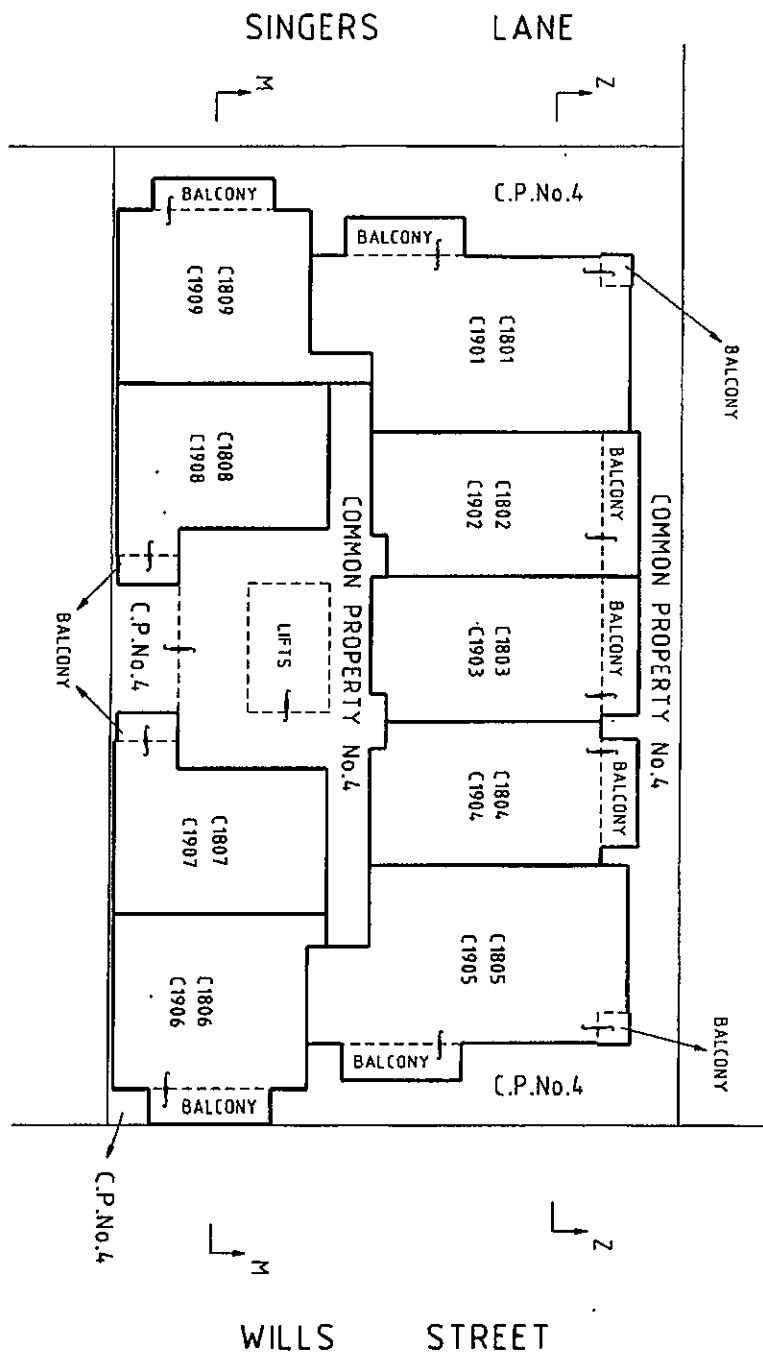
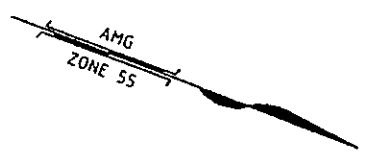

LEVELS EIGHTEEN & NINETEEN



ACN 006 197 235 ABN 44 622 029 694
 BARRINGTON ENGINEERS, PLANNERS
 SURVEYORS, ENGINEERS, CONSULTANTS
 ENVIRONMENTAL CONSULTANTS
 PO BOX 2205 CALVERTON JUNCTION 3161 95284444
 PO BOX 1463 BALLARAT MAIL CENTRE 3354 53118777
 PO BOX 161 LEONGATHA 3953 56622630
 PO BOX 129 MONTAGGI 3985 56721505
 PO BOX 1916 TRARALGON 3844 51760374

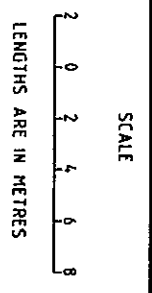

ORIGINAL SCALE 1:200
 SHEET SIZE A3

LICENSED SURVEYOR (PRINT) JOHN FRANCIS WILLIAMS
 SIGNATURE REF. 8455/3 DATE 17/11/2003
 K:\DATA\8455\84550531.DGN VERSION 3

Sheet 36 of 67 Sheets
 DATE / /
 COUNCIL DELEGATE SIGNATURE

PLAN OF SUBDIVISION

STAGE NO.

PLAN NUMBER

PS 444154U

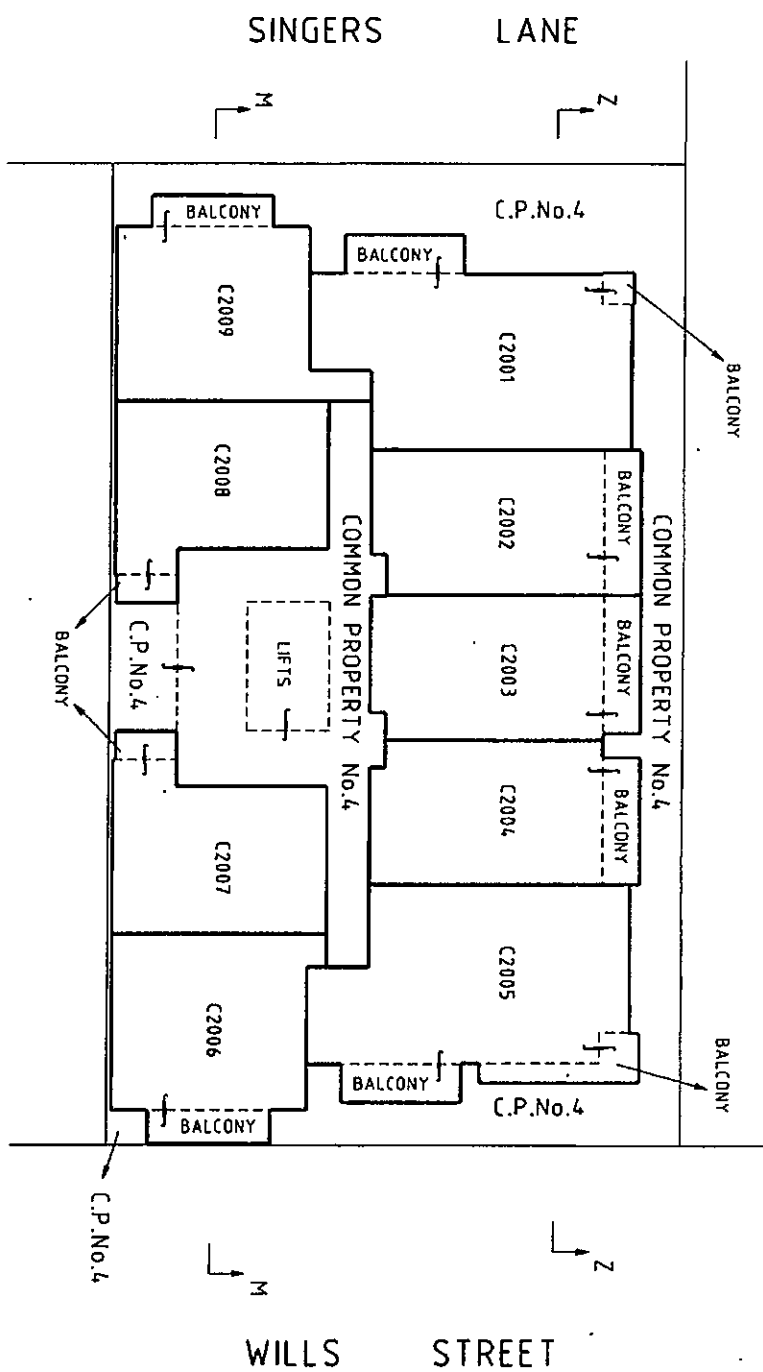
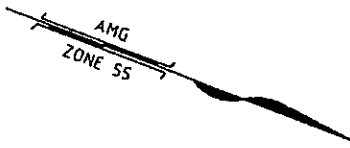

SINGERS LANE

WILLS STREET

LEVEL TWENTY



ACN 006 197 235 ABN 44 622 029 694
 SURVEYORS, ENGINEERS, PLANNERS
 ENVIRONMENTAL CONSULTANTS
 PO BOX 2205 CAULFIELD JUNCTION 3161 95284444
 PO BOX 165 BALLARAT MAIL CENTRE 3354 53138777
 PO BOX 161 LEONGATHA 3953 56622630
 PO BOX 129 MONTAGGI 3995 56721505
 PO BOX 1916 TRARALGON 3844 51760374

SCALE
 2 0 2 4 6 8
 LENGTHS ARE IN METRES

ORIGINAL SCALE SHEET SIZE
 1 : 200 A3

LICENSED SURVEYOR JOHN FRANCIS WILLIAMS
 (PRINT)
 SIGNATURE
 REF. 8455/3
 K:\DATA\8455\8455PSS3.DGN
 DATE 17/11/2003
 VERSION 3

Sheet 37 of 67 Sheets
 DATE / /
 COUNCIL DELEGATE SIGNATURE

PLAN OF SUBDIVISION

STAGE NO.

PLAN NUMBER

PS 444154U

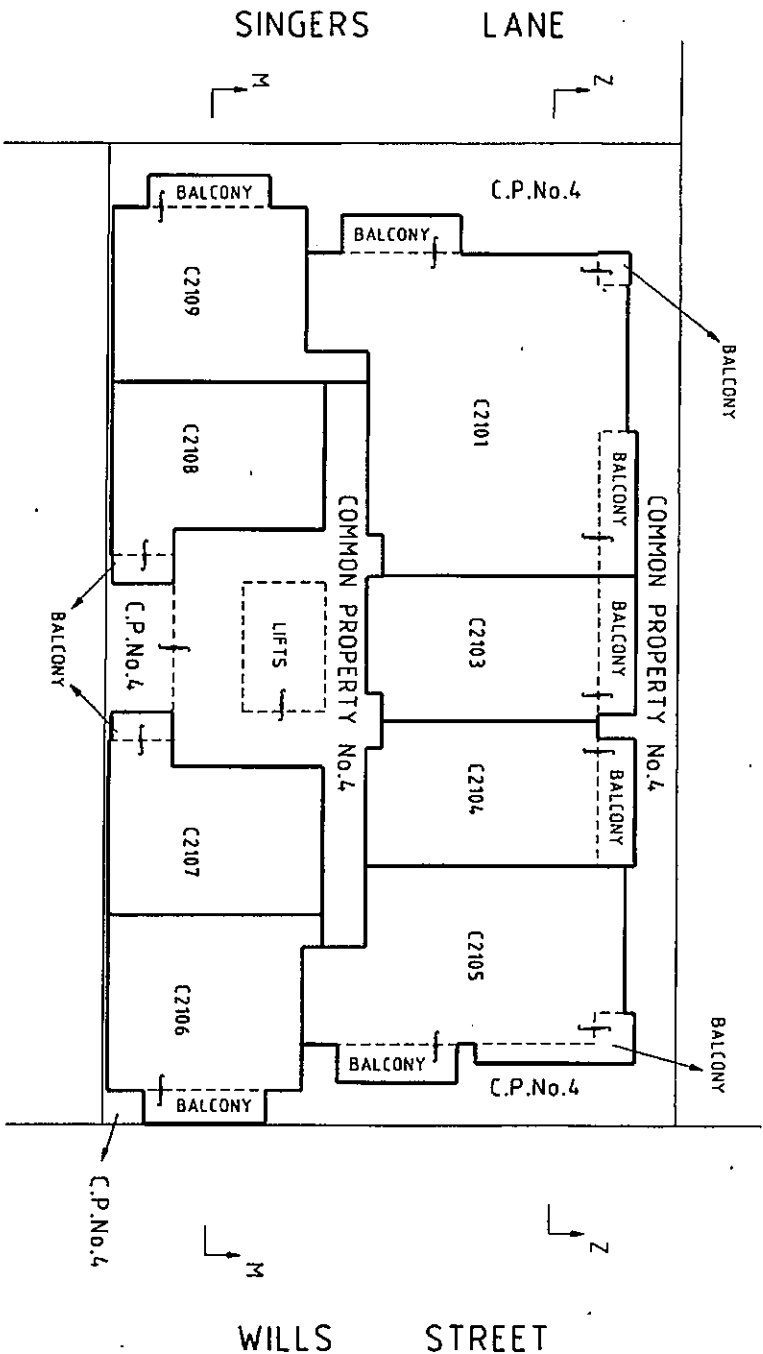
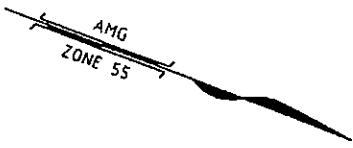

LEVEL TWENTY ONE

BW
 ACN 006 197 235 ABN 44 622 029 694
 SURVEYORS, ENGINEERS, PLANNERS
 ENVIRONMENTAL CONSULTANTS
 PO BOX 2205 CAULFIELD JUNCTION 3161 98284444
 PO BOX 1465 BALELAL MALL CENTRE 3554 53313877
 PO BOX 161 LEONGATHA 3953 56626500
 PO BOX 129 MINTHACCI 3995 56721505
 PO BOX 1916 TRARALGON 3844 51760374

SCALE
 2 0 2 4 6 8
 LENGTHS ARE IN METRES

ORIGINAL SCALE 1:200
 SHEET SIZE A3

LICENSED SURVEYOR (PRINT)
 JOHN FRANCIS WILLIAMS
 REF. 8455/3
 K:\DATA\8455\8455pss3.DGN
 DATE 17/11/2003
 VERSION 3

Sheet 38 of 67 Sheets
 DATE / /
 COUNCIL DELEGATE SIGNATURE

PLAN OF SUBDIVISION

STAGE NO.

PLAN NUMBER

PS 444154U

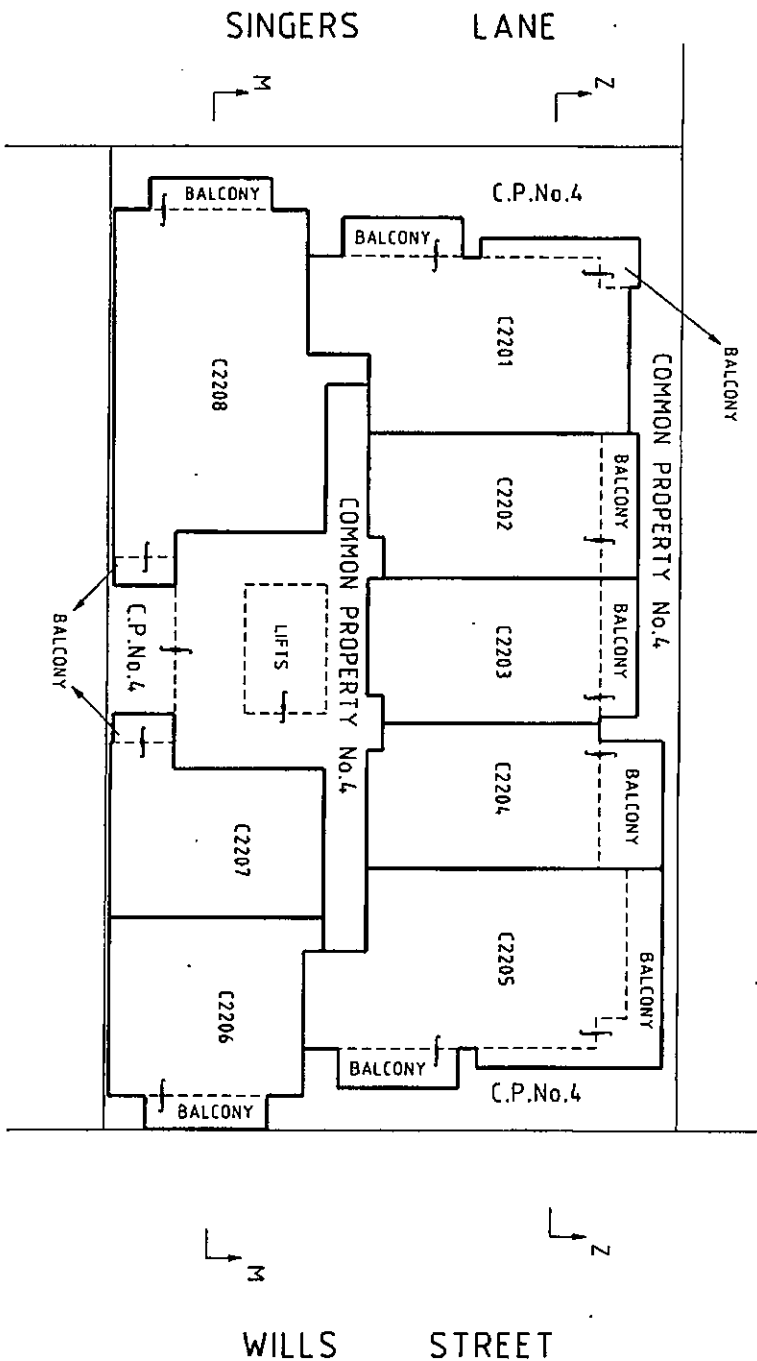
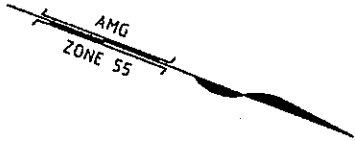

LEVEL TWENTY TWO



ACN 006 197 235 ABR 44 622 029 694
 SURVEYORS, ENGINEERS, PLANNERS
 ENVIRONMENTAL CONSULTANTS
 PO BOX 2205 CAULFIELD JUNCTION 3161 95284444
 PO BOX 1465 BALLARAT CENTRE 3354 53113877
 PO BOX 161 LEONGATHA 3953 56622630
 PO BOX 129 MONTAGUT 3995 56721505
 PO BOX 1916 TRARALGON 3844 51760374

SCALE
 2 0 2 4 6 8
 LENGTHS ARE IN METRES

ORIGINAL SCALE 1:200
 SHEET SIZE A3

LICENSED SURVEYOR (PRINT)
 JOHN FRANCIS WILLIAMS
 SIGNATURE
 REF: 8455/3
 K:\DATA\8455\8455ps3.DGN
 DATE 17/11/2003
 VERSION 3

Sheet 39 of 67 Sheets
 DATE / /
 COUNCIL DELEGATE SIGNATURE

PLAN OF SUBDIVISION

STAGE NO.

PLAN NUMBER

PS 444154U

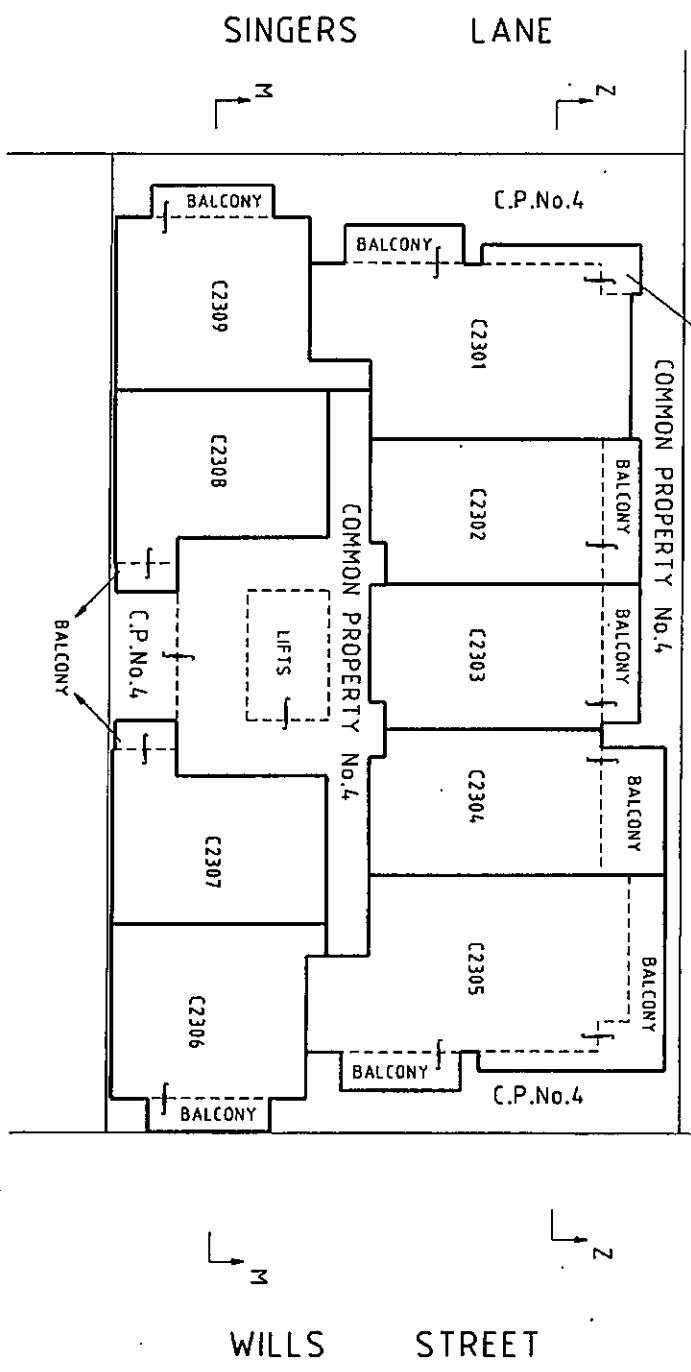

LEVEL TWENTY THREE



ACN 006 197 235 ABN 44 622 029 694
 SURVEYORS, ENGINEERS, PLANNERS
 ENVIRONMENTAL CONSULTANTS
 PO BOX 2205 CAULFIELD JUNCTION 3161 95284444
 PO BOX 1465 BALLARAT MAIL CENTRE 3354 53313877
 PO BOX 161 LEONGATHA 3953 56622630
 PO BOX 129 MONTAGGI 3995 56721505
 PO BOX 1916 TRARALGON 3844 51760374

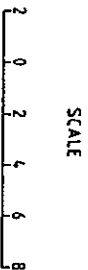

ORIGINAL SCALE 1:200
 SHEET SIZE A3

LICENSED SURVEYOR (PRINT) JOHN FRANCIS WILLIAMS
 SIGNATURE REF. 8455/3 DATE 17/11/2003
 K:\DATA\8455\8455DPS3.DGN VERSION 3

Sheet 40 of 67 Sheets

DATE / /
 COUNCIL DELEGATE SIGNATURE

PLAN OF SUBDIVISION

STAGE NO.

PLAN NUMBER

PS 444154U

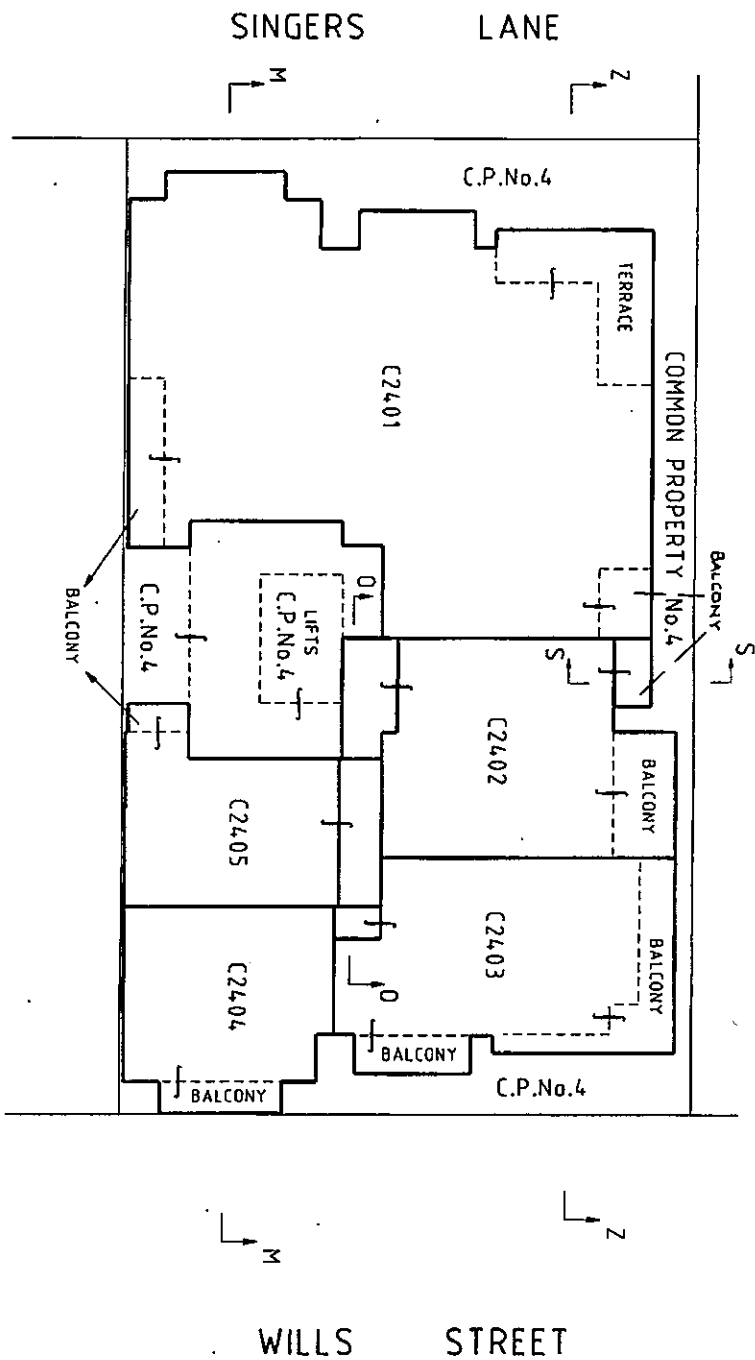

LEVELS TWENTY FOUR & TWENTY FIVE



ACN 006 197 235 ABN 44 622 029 694
 SURVEYORS, ENGINEERS, PLANNERS
 ENVIRONMENTAL CONSULTANTS
 PO BOX 2205 CAULFIELD JUNCTION 3161 95284444
 PO BOX 1465 BALLARAT MAIL CENTRE 3354 53318877
 PO BOX 161 LEONGATHA 3953 56822630
 PO BOX 129 MONTHAGGI 3995 56721505
 PO BOX 1316 TRARALGON 3844 51760374

SCALE
 1 : 200
 LENGTHS ARE IN METRES

ORIGINAL SCALE SHEET
 1 : 200 A3

LICENSED SURVEYOR (PRMT)
 JOHN FRANCIS WILLIAMS
 SIGNATURE REF: 8455/3
 DATE 17/11/2003
 VERSION 3

Sheet 41 of 67 Sheets
 DATE / /
 COUNCIL DELEGATE SIGNATURE

PLAN OF SUBDIVISION	Stage No.	Plan Number
		PS 444154U

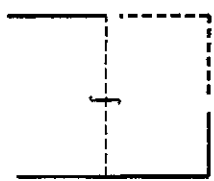

TYPICAL SECTION THROUGH
TERRACES/BALCONIES
NOT TO SCALE

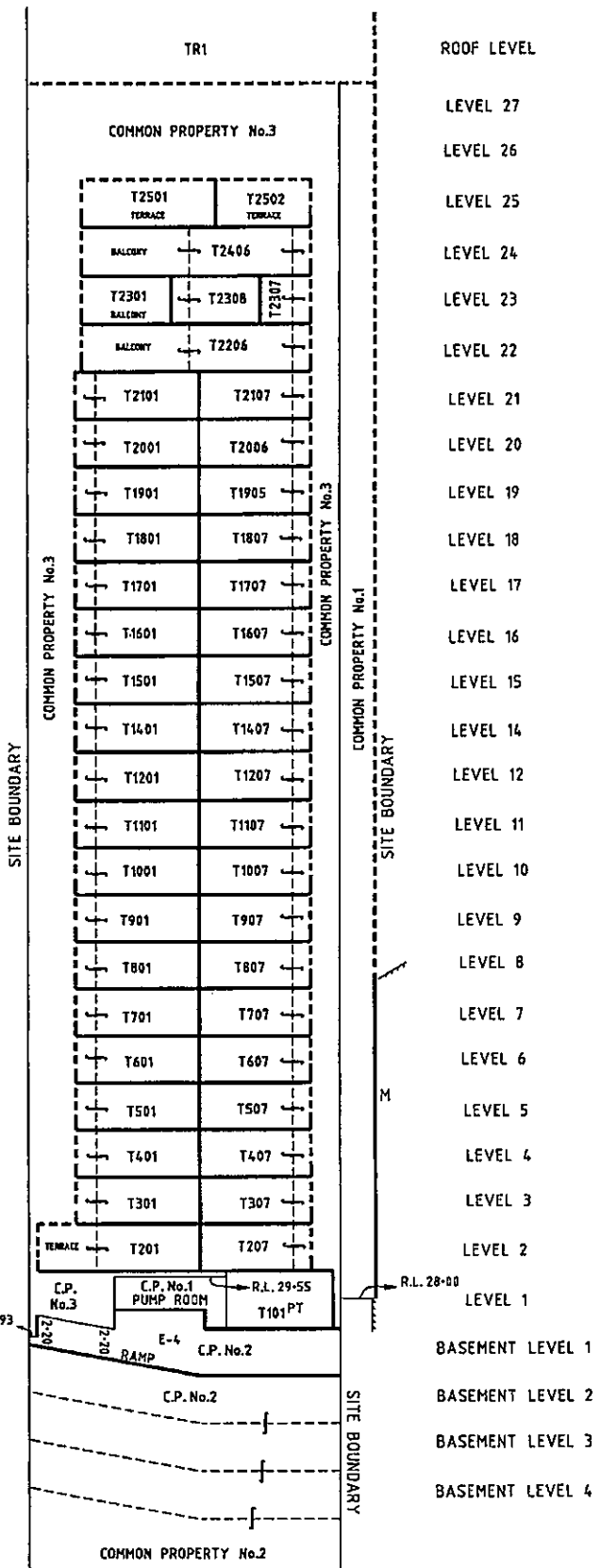

SECTION A-A
NOT TO SCALE

BW	BEVERIDGE WILLIAMS & CO. PTY.LTD.
	ACN 006 197 235 ABN 44 622 029 694
	SURVEYORS . ENGINEERS . PLANNERS
	ENVIRONMENTAL CONSULTANTS
	PO BOX 2205 CAULFIELD JUNCTION 3161 95284444
	PO BOX 1465 BALLARAT MAIL CENTRE 3354 53313877
PO BOX 161 LEDNAGATHA 3953 56622630	
PO BOX 129 WONTHAGGI 3995 56721505	
PO BOX 1916 TRARALGON 3844 51760374	

ORIGINAL
SCALE
SHEET SIZE
A3

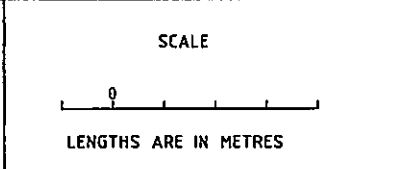

LICENSED SURVEYOR (PRINT)	JOHN FRANCIS WILLIAMS
SIGNATURE	DATE 30/09/2002
REF. K:\DATA\8455\8455pss2.DGN	VERSION 2

Sheet 42 of 67 Sheets
DATE / /
COUNCIL DELEGATE SIGNATURE
Original sheet size A3

PLAN OF SUBDIVISION

STAGE NO.

PLAN NUMBER

PS 444154U

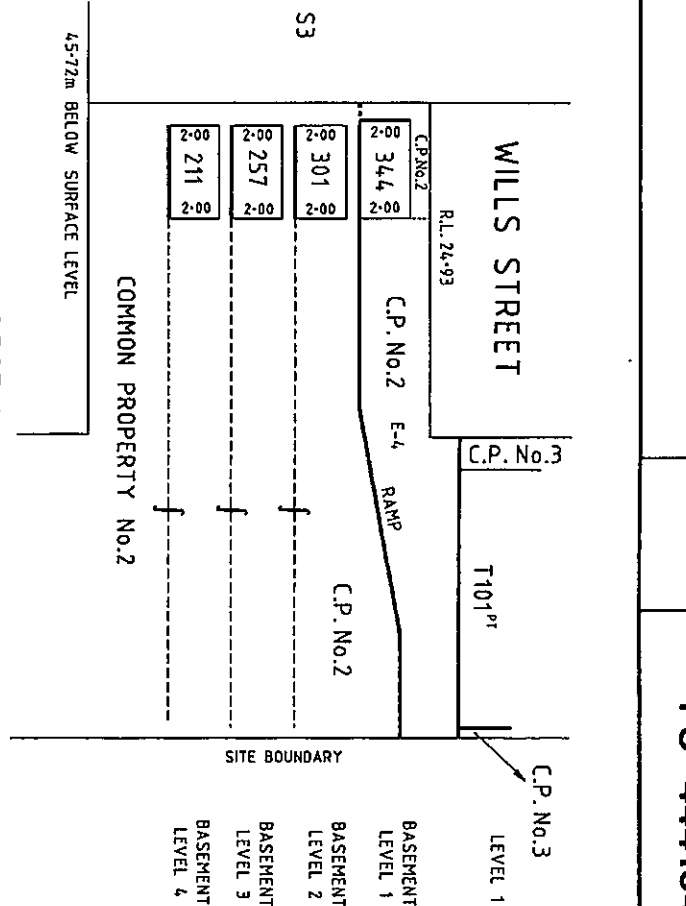
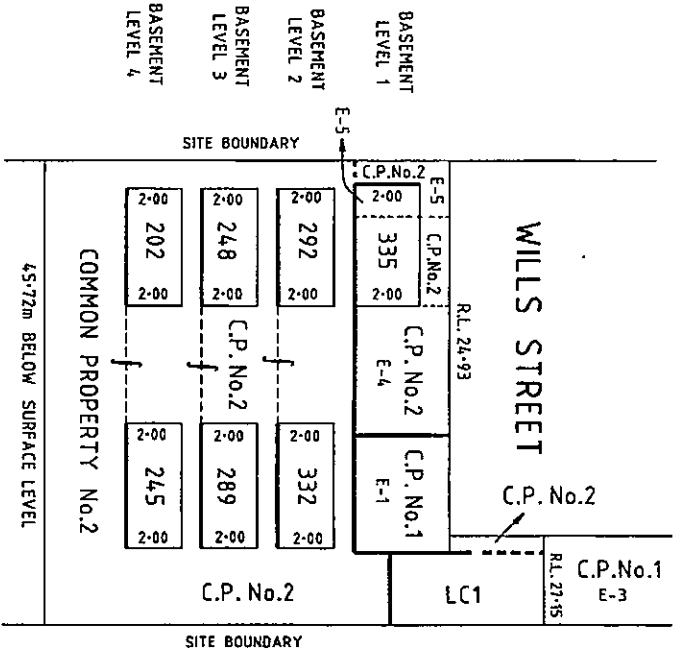

TYPICAL SECTION THROUGH
CARPARK LOTS 201 TO 373
NOT TO SCALE



BEVERIDGE WILLIAMS & CO PTY LTD.
 A/CN 006 197 235
 100 VICTORIA AVENUE, SUITE 100, MELBOURNE VIC 3000
 PH 03 9412 4200 FAX 03 9412 4201
 PO BOX 129 WENTWORTHVILLE NSW 2145
 PH 02 9615 1200 FAX 02 9615 1201
 PO BOX 129 WENTWORTHVILLE NSW 2145
 PH 02 9615 1200 FAX 02 9615 1201

SCALE



ORIGINAL SCALE

SHEET SIZE A3

LICENSED SURVEYOR (PRINT) JOHN FRANCIS WILLIAMS

DATE 30/09/2002

Sheet 43 of 67 Sheets

SIGNATURE (PRINT) REF: K:\DATA\8455\8455ps2.DGN

VERSION 2

DATE / / COUNCIL DELEGATE SIGNATURE

PLAN OF SUBDIVISION	Stage No.	Plan Number
		PS 444154U

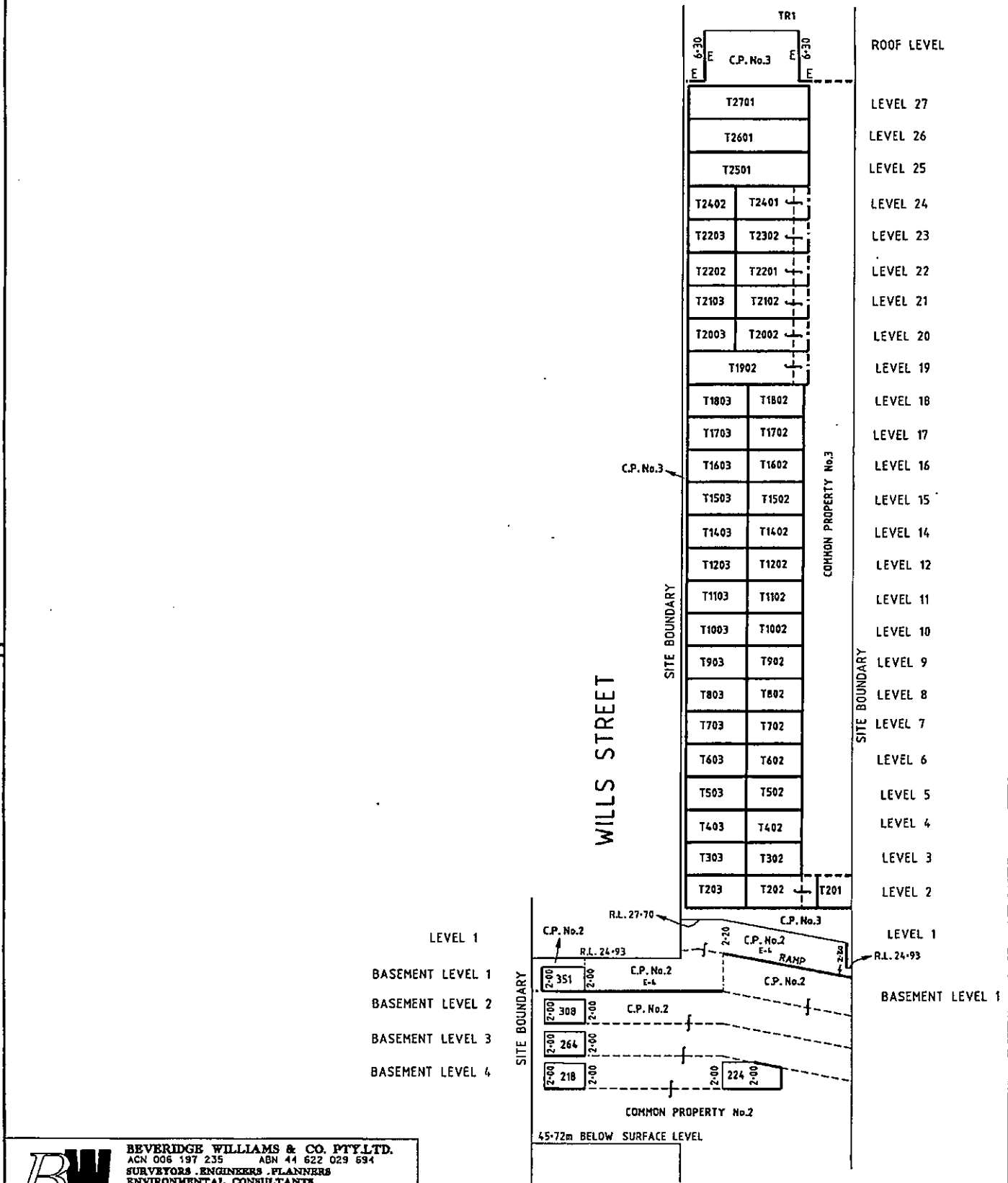

BW BEVERIDGE WILLIAMS & CO. PTY.LTD.
 ACN 006 197 235 ABN 44 622 029 694
 SURVEYORS ENGINEERS PLANNERS
 ENVIRONMENTAL CONSULTANTS
 PO BOX 2205 CAULFIELD JUNCTION 3161 95284444
 PO BOX 1465 BALLARAT MAIL CENTRE 3354 53313877
 PO BOX 161 LEONGATHA 3953 56622630
 PD BOX 129 WONTHAGGI 3995 56721505
 PD BOX 1916 TRARALGON 3844 51760374

ORIGINAL
 SCALE SHEET SIZE
 A3

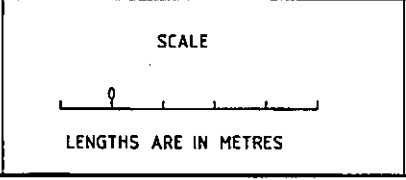

LICENSED SURVEYOR JOHN FRANCIS WILLIAMS
 (PRINT)
 SIGNATURE _____ DATE 30/09/2002
 REF. 8455/2A
 K:\DATA\8455\8455pss2.DGN VERSION 2

Sheet 44 of 67 Sheets

DATE / /
 COUNCIL DELEGATE SIGNATURE
 Original sheet size A3

PLAN OF SUBDIVISION

STAGE NO.

PLAN NUMBER
PS 444154U

WILLS STREET

SITE LEVEL
 BASEMENT LEVEL 1
 BASEMENT LEVEL 2
 BASEMENT LEVEL 3
 BASEMENT LEVEL 4

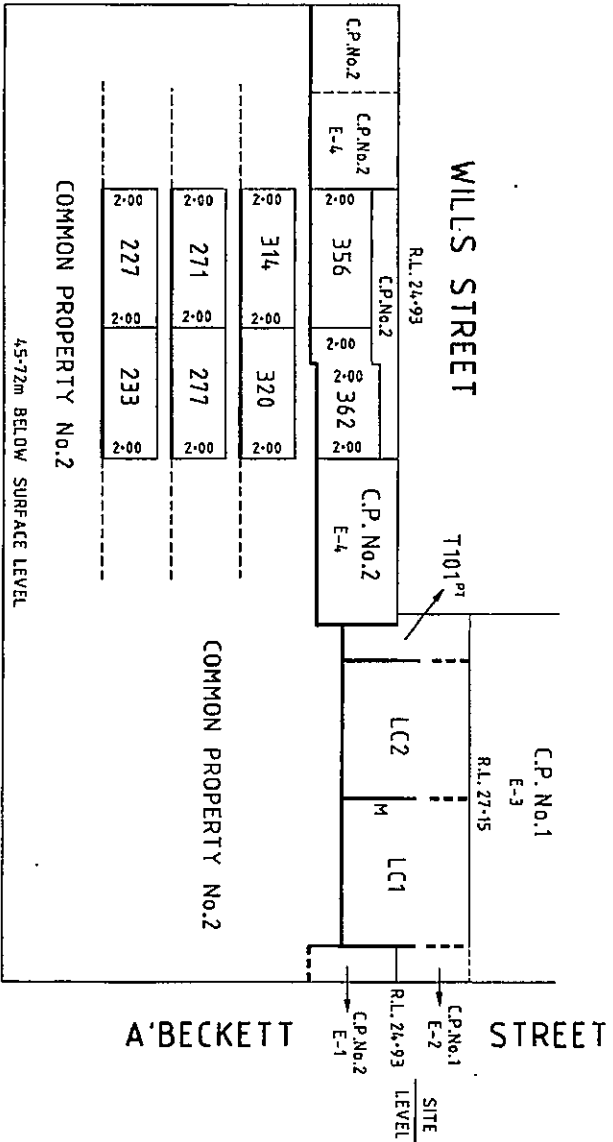

SECTION E-E

NOT TO SCALE



BEVERIDGE WILLIAMS & CO. PTY LTD.
 ACN 006 197 235
 RIVERVIEW ENGINEERS PLANNERS
 ENVIRONMENTAL CONSULTANTS
 PO BOX 2205 GOLF FIELDS JUNCTION 3181 95294444
 PO BOX 1465 BELLARINE MAIL CENTRE 3554 53358777
 PO BOX 151 LEONORA 3552 9872505
 PO BOX 1816 TRARALGOON 3844 91759174

SCALE

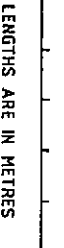

ORIGINAL SCALE SHEET SIZE

A3

LICENSED SURVEYOR **JOHN FRANCIS WILLIAMS**

SIGNATURE **8455/2A**
 REF. K:\DATA\8455\8455052.DGN

DATE 30/09/2002

VERSION 2

Sheet 45 of 67 Sheets

DATE / /
 COUNCIL DELEGATE SIGNATURE

PLAN OF SUBDIVISION

Stage No. _____ Plan Number
PS 444154U

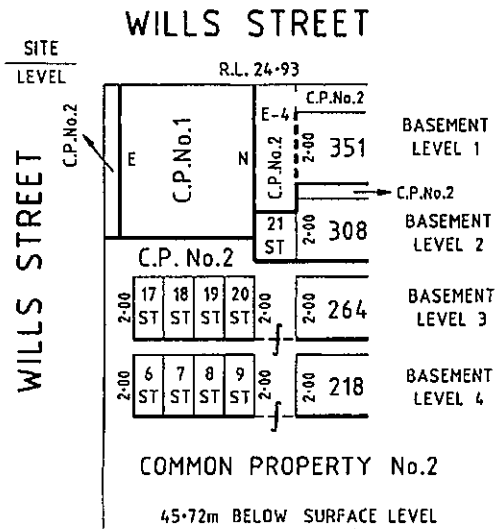

SECTION G-G
NOT TO SCALE

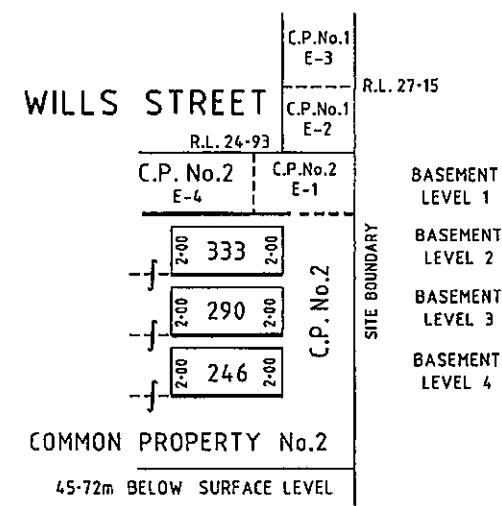

SECTION H-H
NOT TO SCALE

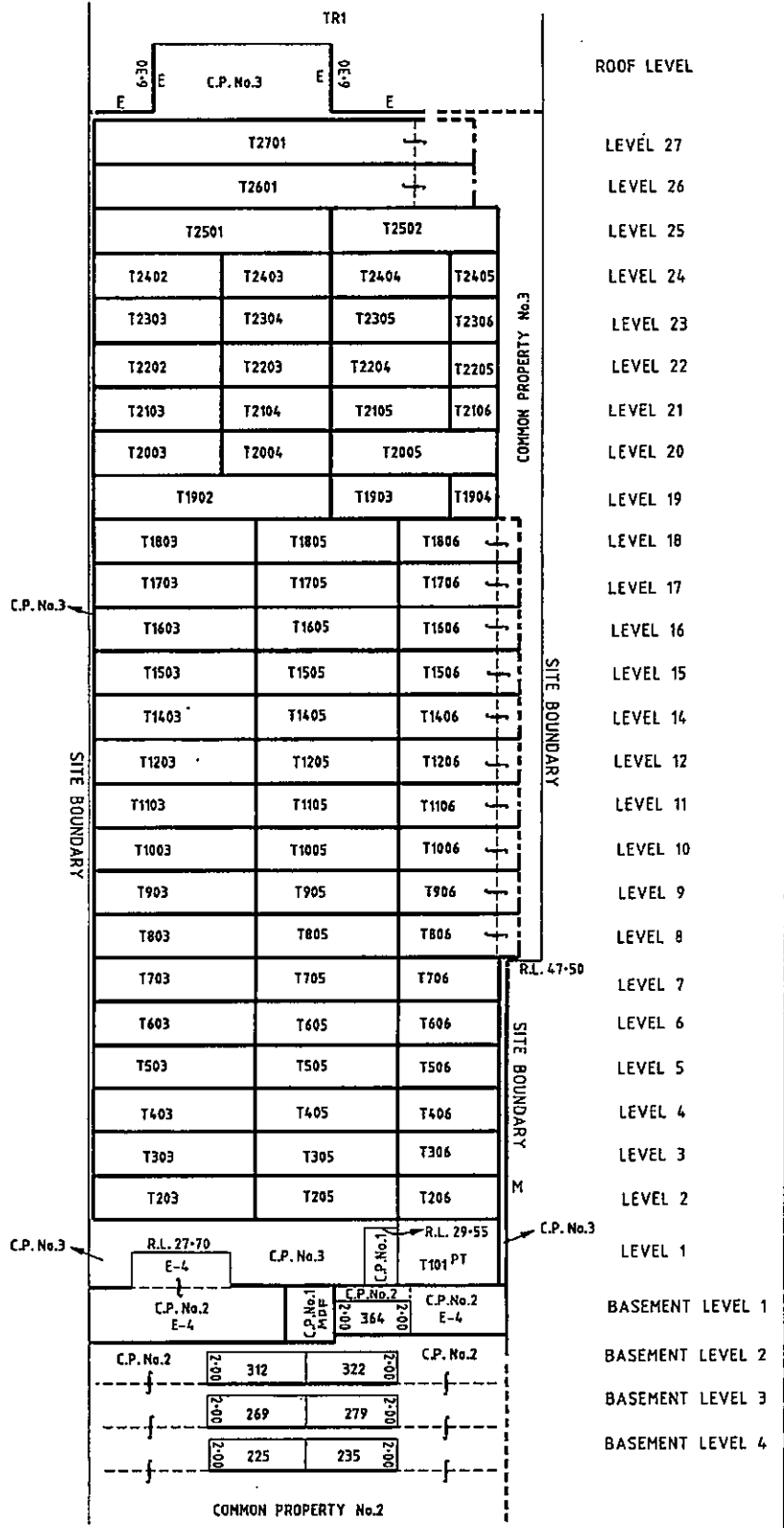

SECTION F-F
NOT TO SCALE

BW BEVERIDGE WILLIAMS & CO. PTY.LTD.
ACN 006 197 235 ABN 44 622 029 694
SURVEYORS, ENGINEERS, PLANNERS
ENVIRONMENTAL CONSULTANTS
PO BOX 2205 CAULFIELD JUNCTION 3161 95284444
PO BOX 1465 BALLARAT MAIL CENTRE 3354 53313877
PO BOX 161 LEONGATHA 3953 56622630
PO BOX 129 WONTHAGGI 3995 56721505
PO BOX 1916 TRARALGON 3844 51760374

LICENSED SURVEYOR JOHN FRANCIS WILLIAMS
(PRINT)

SIGNATURE _____ DATE 30/09/2002

8455/2A

REF. K:\DATA\8455\8455pss2.DGN VERSION **2**

Sheet 46 of 67 Sheets

DATE / /

COUNCIL DELEGATE SIGNATURE _____

Original sheet size A3

ORIGINAL SCALE

SCALE

SHEET SIZE
A3

LENGTHS ARE IN METRES

PLAN OF SUBDIVISION

STAGE NO.

PLAN NUMBER
PS 444154U

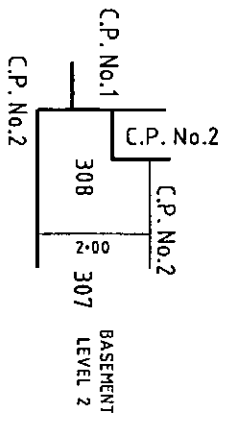

SECTION K-K
NOT TO SCALE

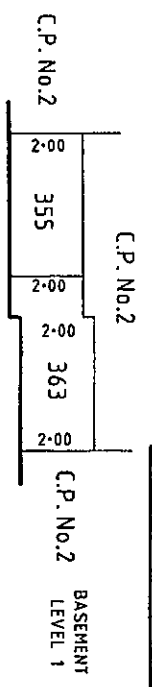

SECTION L-L
NOT TO SCALE

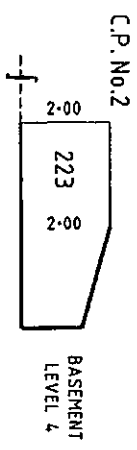

SECTION J-J
NOT TO SCALE

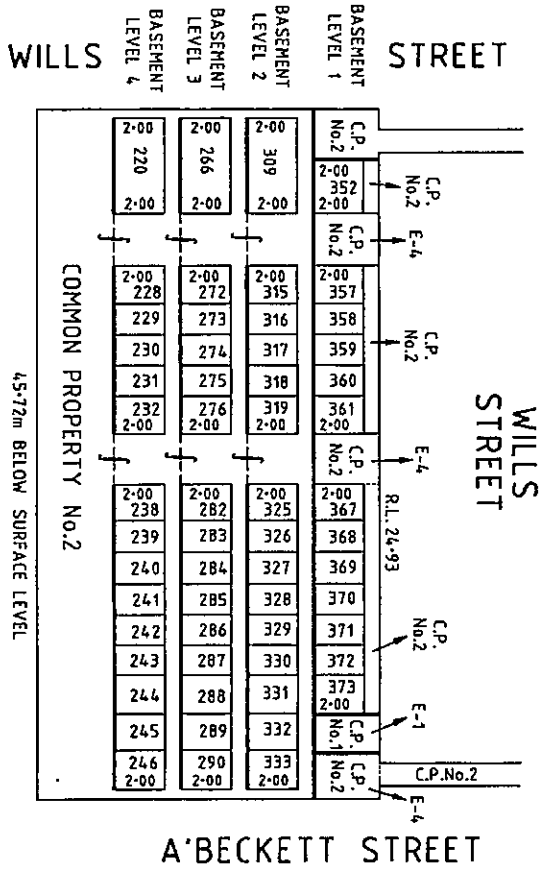

SECTION X-X
NOT TO SCALE

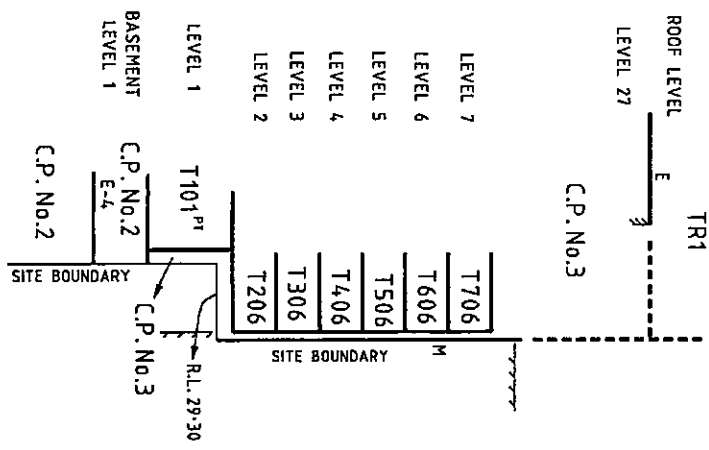

SECTION Y-Y
NOT TO SCALE



BEVERIDGE WILLIAMS & CO. PTT/ATA
 ACN 006 197 235 ABR 44 622 029 694
 ROYALTYAL ENGINEERS PLANNERS
 10 BOX 2205 THE STRAIT TIMES
 PO BOX 1465 BALLARAT MAIL CENTRE 3194 5313317
 PO BOX 161 LEONGATHA 3953 5662260
 PO BOX 129 WORTHAGGI 3985 66721505
 PO BOX 1916 TORRALGON 3844 51760374

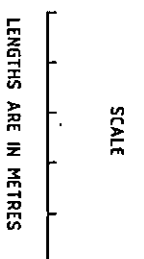

ORIGINAL SCALE

SHEET SIZE A3

LENGTHS ARE IN METRES

LICENSED SUPERVISOR (PRINT) **JOHN FRANCIS WILLIAMS**

SIGNATURE **8455/2A**

REF. K:\DATA\8455\8455ps2.dgn

DATE **30/09/2002**

VERSION **2**

Sheet 47 of 67 Sheets

DATE / /
COUNCIL DELEGATE SIGNATURE

C.P. No.2

Basement Level One	2.00
Basement Level One	2.00

S2

TYPICAL SECTION THROUGH CARPARK
LOTS 334 TO 351 & 354 TO 373
NOT TO SCALE

SINGERS LANE

See Sheet 51
For Continuation

- BASEMENT LEVEL 1
- BASEMENT LEVEL 2
- BASEMENT LEVEL 3
- BASEMENT LEVEL 4

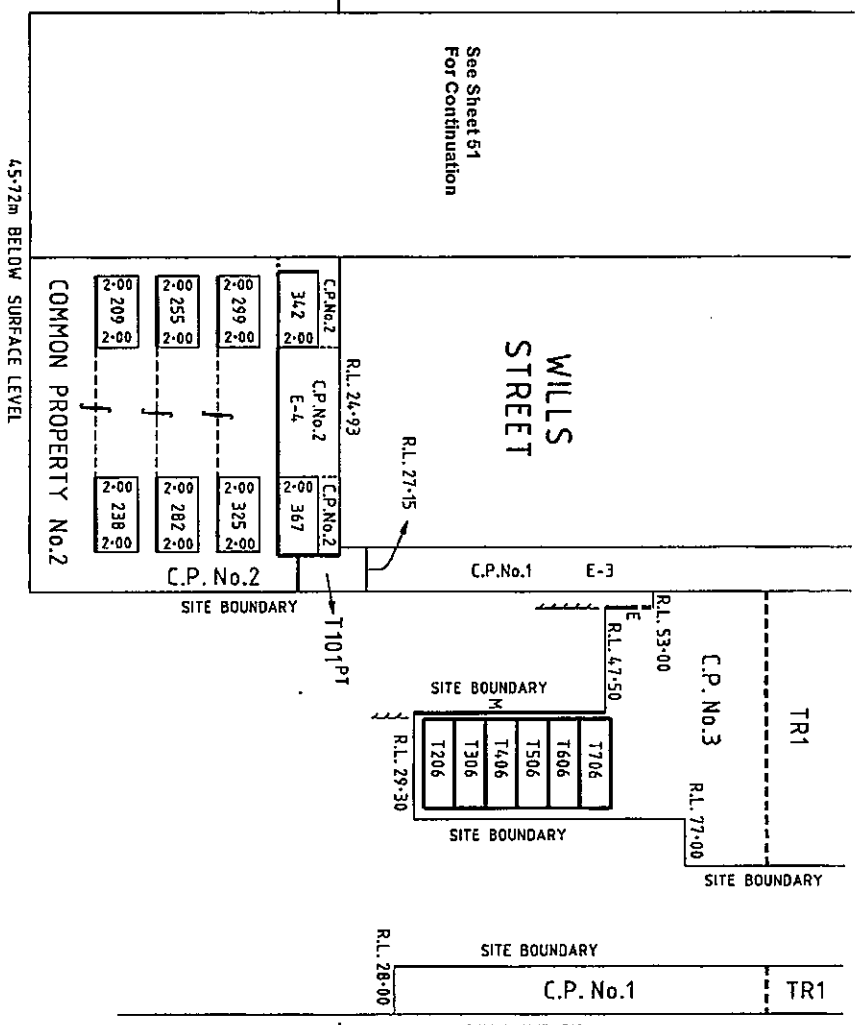

SECTION Z-Z
NOT TO SCALE

45-72m BELOW SURFACE LEVEL

PLAN OF SUBDIVISION

STAGE NO.

PLAN NUMBER

PS 444154U



B W WILLIAMS & CO PTY LTD
 21 RIVERVIEW BLVD
 RIVERSIDE, MELBOURNE VIC 3066
 ENVIRONMENTAL CONSULTANTS
 PO BOX 2205 CALFELD JUNCTION 3161 95294444
 PO BOX 1469 BALLARAT MAIL CENTRE 3354 5313877
 PO BOX 161 LEONGATHA 3653 56622630
 PO BOX 128 MONTYAGOI 3955 56721505
 PO BOX 1916 TRARALGON 3444 51760374

SCALE



LENGTHS ARE IN METRES

ORIGINAL SCALE SHEET SIZE A3

LICENSED SURVEYOR (PRINT)
 JOHN FRANCIS WILLIAMS
 SIGNATURE
 REF. K:\DATA\8455\8455pss2.DGN

DATE 30/09/2002

VERSION 2

Sheet 48 of 67 Sheets

DATE / / COUNCIL DELEGATE SIGNATURE

PLAN OF SUBDIVISION

Stage No.

Plan Number

PS 444154U

TYPICAL SECTION THROUGH TERRACES/BALCONIES

NOT TO SCALE

ROOF LEVEL

- LEVEL 25
- LEVEL 24
- LEVEL 23
- LEVEL 22
- LEVEL 21
- LEVEL 20
- LEVEL 19
- LEVEL 18
- LEVEL 17
- LEVEL 16
- LEVEL 15
- LEVEL 14
- LEVEL 13
- LEVEL 12
- LEVEL 11
- LEVEL 10
- LEVEL 9
- LEVEL 8
- LEVEL 7
- LEVEL 6
- LEVEL 5
- LEVEL 4
- LEVEL 3
- LEVEL 2
- LEVEL 1

SINGERS LANE

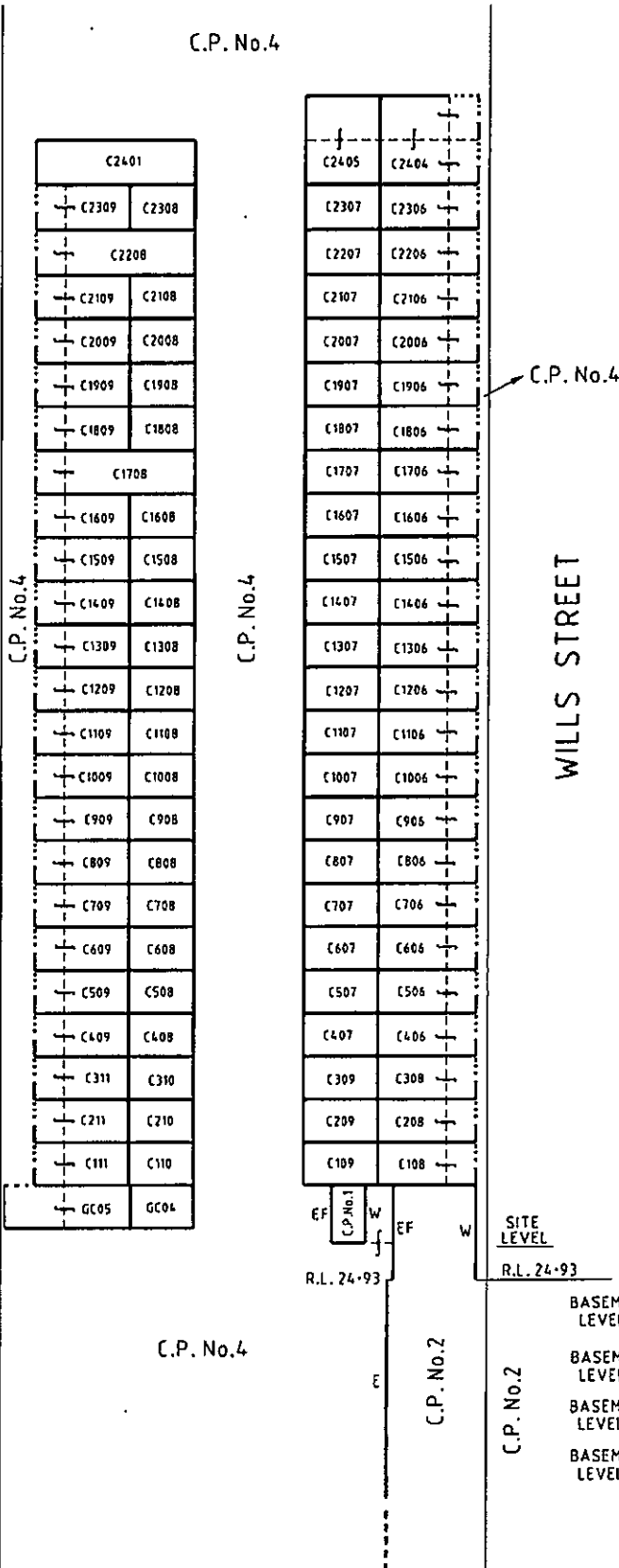

SITE LEVEL

GROUND FLOOR
BASEMENT LEVEL 1

R.L. 24.93

SITE LEVEL

R.L. 24.93

- BASEMENT LEVEL 1
- BASEMENT LEVEL 2
- BASEMENT LEVEL 3
- BASEMENT LEVEL 4

SECTION M-M

NOT TO SCALE



BEVERIDGE WILLIAMS & CO. PTY. LTD.
 ACN 006 197 235 ABN 44 622 029 694
 SURVEYORS, ENGINEERS, PLANNERS
 ENVIRONMENTAL CONSULTANTS
 PO BOX 2205 CAULFIELD JUNCTION 3161 95284444
 PO BOX 1465 BALLARAT MAIL CENTRE 3354 53313877
 PO BOX 161 LEONGATHA 3953 56622630
 PO BOX 129 WINTHAGGI 3995 56721505
 PO BOX 1916 TRARALGON 3844 51760374

45-72m BELOW SURFACE LEVEL

Sheet 49 of 67 Sheets

ORIGINAL

SCALE

LICENSED SURVEYOR (PRINT) **JOHN FRANCIS WILLIAMS**

SIGNATURE _____ DATE 17/11/2003

REF. 8455/3
K:\DATA\8455\8455pss3.DGN

VERSION 3

DATE / /

COUNCIL DELEGATE SIGNATURE

Original sheet size A3

SCALE SHEET SIZE
A3

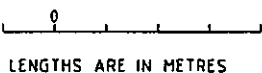

PLAN OF SUBDIVISION

STAGE NO.

PLAN NUMBER

PS 444154U

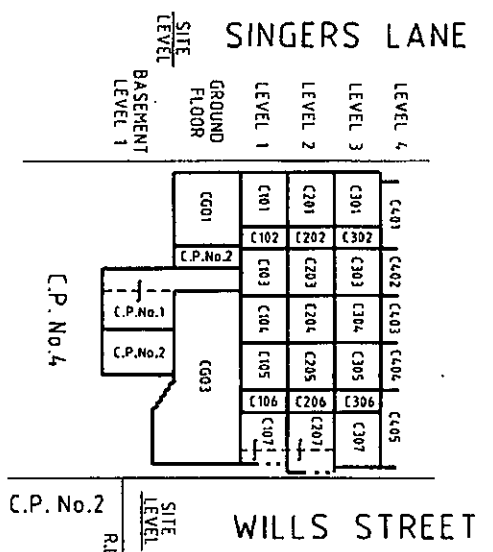

SECTION N-N

NOT TO SCALE

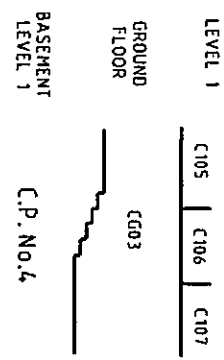

SECTION Q-Q

NOT TO SCALE

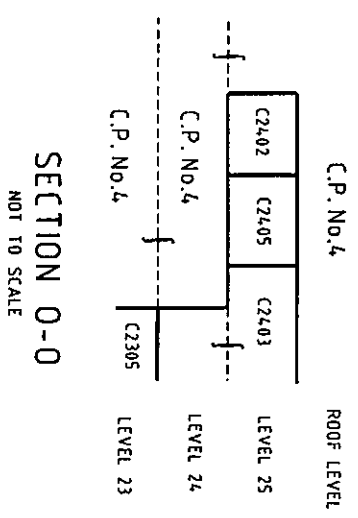
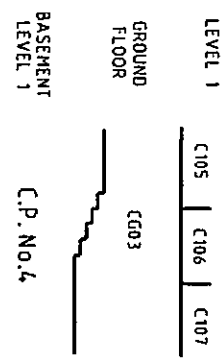

SECTION O-O

NOT TO SCALE

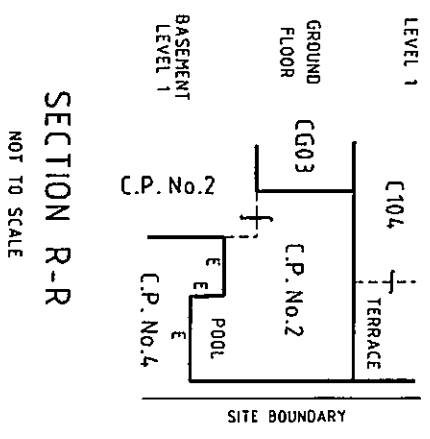

SECTION R-R

NOT TO SCALE

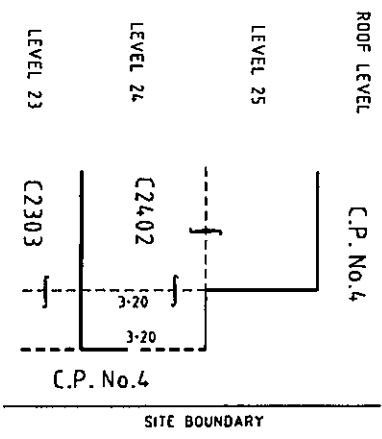

SECTION S-S

NOT TO SCALE



BEVERIDGE WILLIAMS & CO. PTY.LTD.
 LIC. NO. 91725
 ENVIRONMENTAL ENGINEERS, PLANNERS
 ENVIRONMENTAL CONSULTANTS
 PO BOX 2205 CAULFIELD JUNCTION 3161 95264444
 PO BOX 145 BALLARAT W.A.I. CENTRE 3354 5313877
 PO BOX 161 LENDONGTHA 3953 56622630
 PO BOX 129 MONTICOMI 3955 56721505
 PO BOX 1916 TRARLGOON 3844 51760374

SCALE

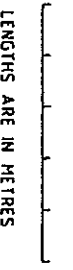

ORIGINAL
 SCALE SHEET
 SIZE A3

LICENSED SUPERVISOR
 (PRINT) JOHN FRANCIS WILLIAMS

SIGNATURE REF. 8455/3 DATE 17/11/2003

K:\DATA\8455\8455083.DGN VERSION 3

Sheet 50 of 67 Sheets

DATE / /
 COUNCIL DELEGATE SIGNATURE

PLAN OF SUBDIVISION

STAGE NO. PLAN NUMBER
PS 444154U

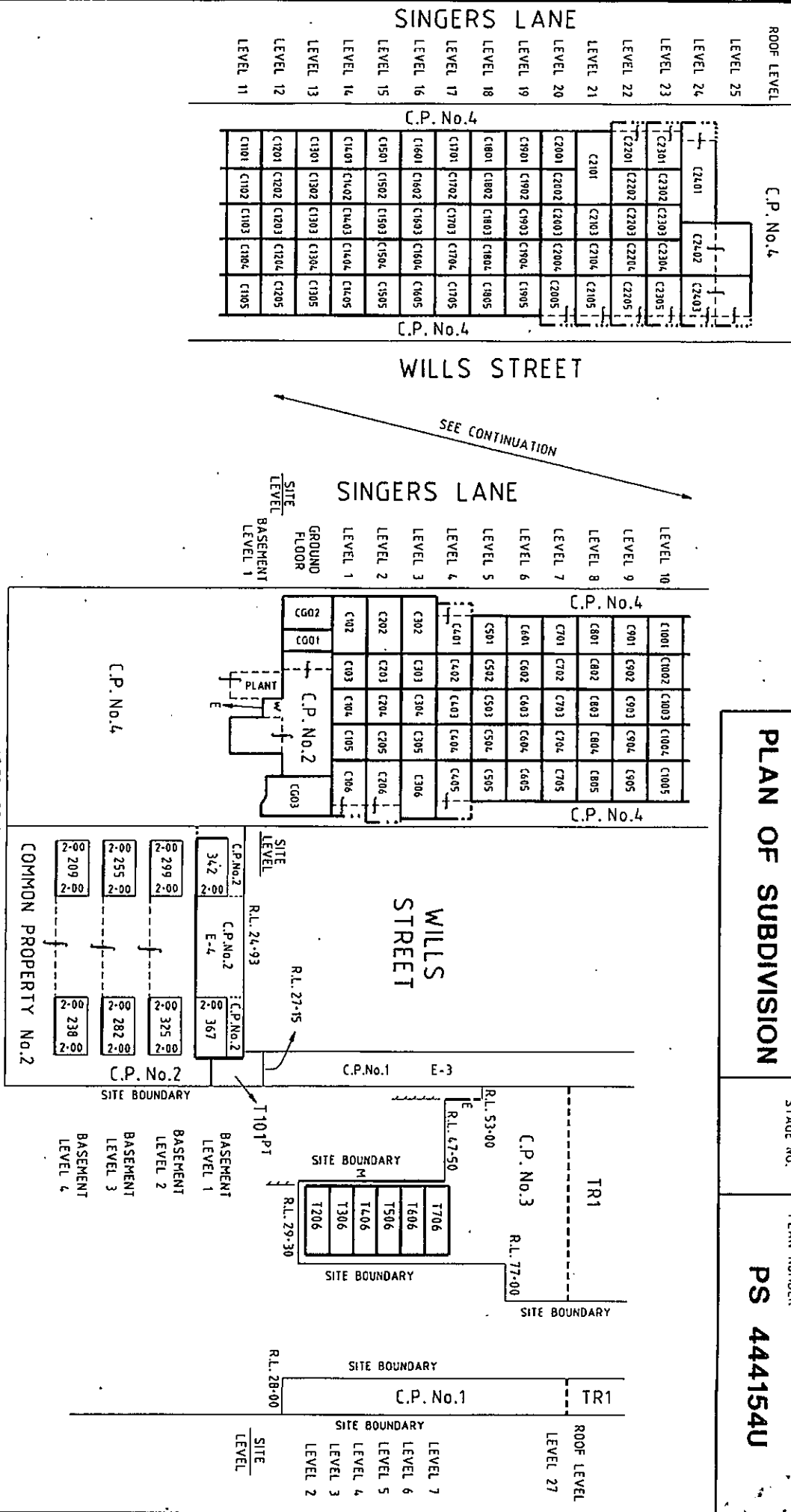
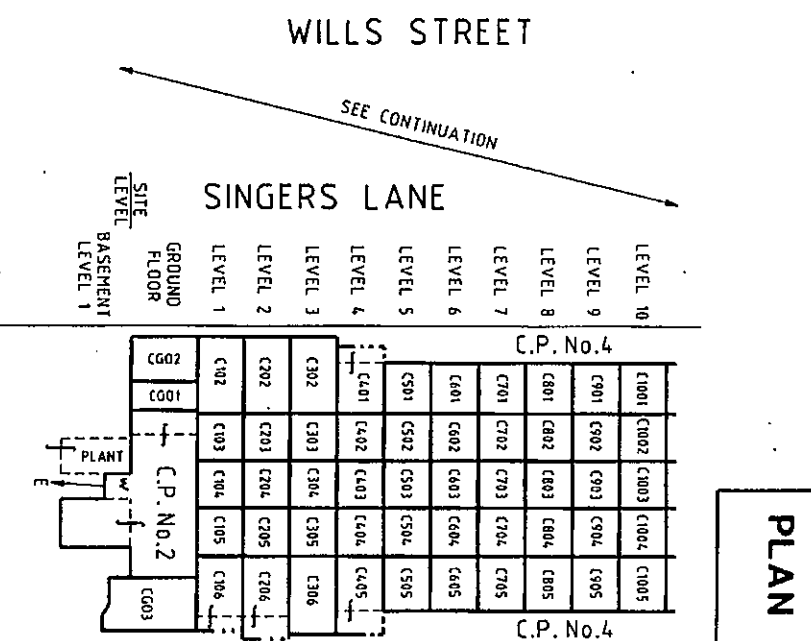
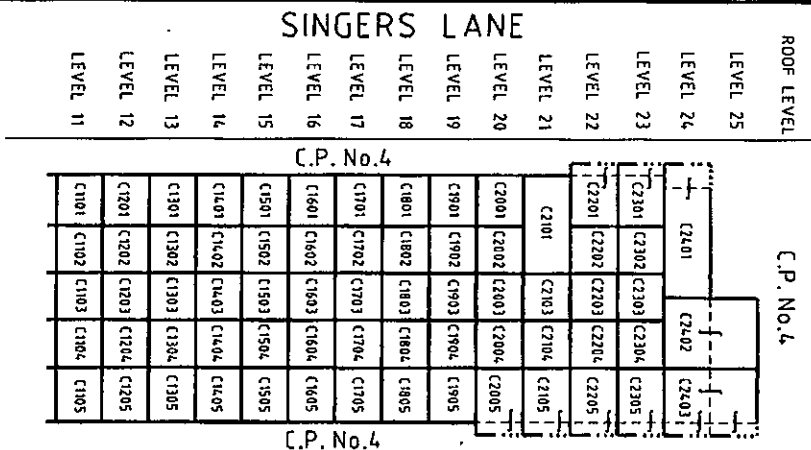

SECTION Z-Z

NOT TO SCALE

SCALE

ORIGINAL SCALE

SHEET SIZE

LICENSED SURVEYOR

Sheet 21 of 67 Sheets

BW
 BEVERIDGE WILLIAMS & CO. PTX.LTD.
 LIC. NO. 006 197 235
 SURVEYORS, ENGINEERS, PLANNERS,
 ENVIRONMENTAL CONSULTANTS
 PO BOX 2205 CALLEJO JUNCTION 3161 95284444
 PO BOX 1465 BALLARAT MAIL CENTRE 3154 5311877
 PO BOX 161 LEONGATHA 3953 5662830
 PO BOX 129 MONTAGNA 3995 56721905
 PO BOX 1916 TRARALGON 3844 51760374

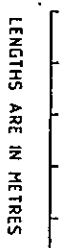

LENGTHS ARE IN METRES

SIGNATURE

DATE 17/11/2003

DATE / /
 COUNCIL DELEGATE SIGNATURE

PS444154U

Additional Rules

BODY CORPORATE NO. 1

ALL LOTS, OTHER THAN LOTS LC1 & LC2, AT OR BELOW BASEMENT LEVEL 1 ON THIS PLAN CAN ONLY BE USED FOR CAR PARKING OR STORAGE PURPOSES BY THE OWNERS AND OCCUPIERS OF, AND VISITORS TO LOTS ABOVE BASEMENT LEVEL 1 ON THIS PLAN OR BY THE OWNERS AND OCCUPIERS OF, AND VISITORS TO LOTS ON PS 432495J

Owners corporation information
formerly contained on Sheets

52, 53, 54, 55, 56, 57, 58, 59, 60,
61, 62, 63, 64, 65, 66 & 67

of this plan is now available in the
Owners Corporation Search Report

Sheets

53, 54, 55, 56, 57, 58, 59, 60, 61,
62, 63, 64, 65, 66 & 67

have been removed from this plan

MODIFICATION TABLE

RECORD OF ALL ADDITIONS OR CHANGES TO THE PLAN

MASTER PLAN (STAGE ONE) REGISTERED DATE:15/2/02 TIME: 12.33PM

WARNING: THE IMAGE OF THIS PLAN/DOCUMENT HAS BEEN DIGITALLY AMENDED.
NO FURTHER AMENDMENTS ARE TO BE MADE TO THE ORIGINAL PLAN/DOCUMENT.

PLAN NUMBER

PS444154U

AFFECTED LAND/PARCEL	LAND/PARCEL IDENTIFIER CREATED	MODIFICATION	DEALING NUMBER	DATE	TIME	EDITION NUMBER	ASSISTANT REGISTRAR OF TITLES
LOT S2	SEE STAGE 2	STAGE 2	PS444154U/S2	6/12/02	12.20PM	2	GREG NEWMAN
LOT S3	SEE STAGE 3	STAGE 3	PS444154U/S3	10/12/03		3	C J H
THIS PLAN BODY CORPORATE No. 1		CHANGE OF ADDRESS	AC684830Y	24/02/04		4	Robert Redman
BODY CORPORATE No 2		CHANGE OF ADDRESS	AD415007A	04/02/05		5	MLE
BODY CORPORATE No 3		CHANGE OF ADDRESS	AD415019S	04/02/05		5	MLE
BODY CORPORATE No 4		CHANGE OF ADDRESS	AD415015B	04/02/05		5	MLE
THIS PLAN		RECTIFICATION (CROWN DESCRIPTION)	AD458770U	22/02/05		6	TT.O.