

An Important Safety Letter From Your Building's Facility Manager

Dear Residents

Safe Maintenance of Your Balcony / Courtyard space

Please take the time to read the MFB Flyer attached to this letter. And diligently follow the instructions on it to maintain a safe space within your balcony / courtyard area.

You will have seen or heard on the news about fires starting on Balconies of Multi Apartment buildings. Residents being evacuated from the building, and in some cases not being allowed back into the building for quite some time, all very worrying and extremely inconvenient for all concerned.

These have been caused generally by either;

- A) Flammable materials being stored on the balcony or courtyard, being set on fire by a discarded cigarette from either the balcony or another balcony above.
(Therefore, make sure if anyone smokes on your balcony / courtyard, the cigarette is fully extinguished, and only use a SOLID, HEAVY, HIGH SIDED ASH TRAY)
And do not use lighted candles on your balcony / courtyard.

- B) Air con units being caused to fault, overheat and catch fire due to materials blocking air flow to the motors, and those flammable materials also catching fire and spreading the flames.
(Therefore, do not store any materials within a metre of your Air Con unit).

These issues are of utmost importance to the safety of all residents in the building.

Residents (Balconies / Courtyards) that do not abide by these building balcony safety requirements.

Will be issued a Building Safety Breach Notice, that will be sent to the apartment owner.

We encourage concerned residents to report to us, any balcony area they feel is not being maintained in a safe condition. So that we can follow up with the owner and/or resident.

Yours Sincerely

Tony Constable

Director

FIRE SAFETY ON BALCONIES

Important safety advice from the City of Melbourne and the Metropolitan Fire Brigade (MFB) to help reduce the risk of fires starting and spreading from balconies to exterior walls and adjoining apartments.

Please take the following actions immediately to ensure your safety and prevent property damage.

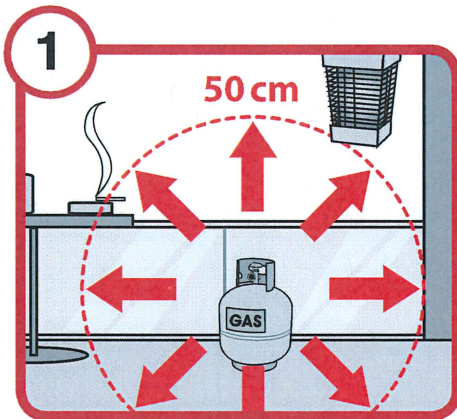

1 Always store gas bottles outside, upright and away from sources of heat.

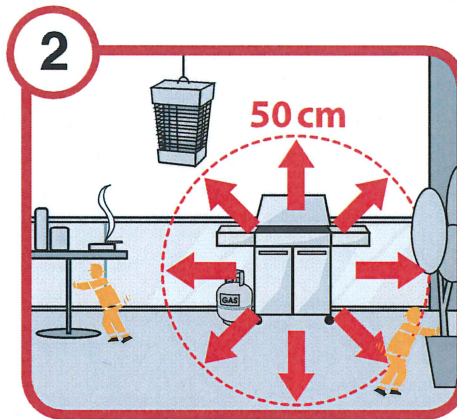

2 When using a barbecue maintain a safe distance of 50 cm from exterior walls, anything else that could burn, as well as any electrical ignition sources.



3 Smokers should use heavy, high-sided ashtrays (made of glass, ceramic or metal) to prevent them tipping over. Always fully extinguish cigarettes.



4 Remove rubbish, clutter and flammable items from balconies and keep furniture away from exterior walls.

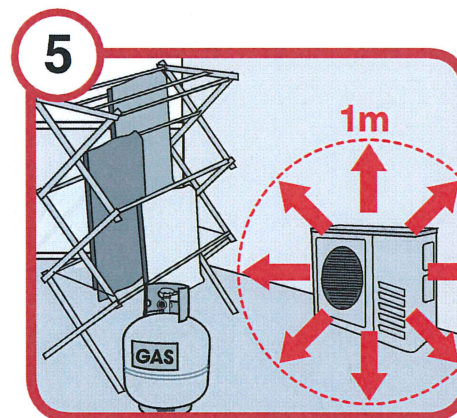

5 Keep goods, materials and clothes a safe distance of 1 metre clear of air conditioner units



6 Keep a dry powder fire extinguisher easily accessible. Use only in case of a small fire and if you feel physically and mentally able.

For further information on fire safety, MFB's Home Fire Safety booklet (accessible in English and 21 other languages) is available at: www.mfb.vic.gov.au

For further information on gas safety, visit the Energy Safe Victoria website at: www.esv.vic.gov.au

For Translating and Interpreting Service, contact 13 14 50.

In case of a fire, call 000 (triple zero)